



Instruction Manual

Before install or operate the product, Please read the Operation Instruction carefully, and keep it for use and standby

NVF2G Series Inverter

ZHEJIANG CHINT ELECTRICS CO., LTD.

Add : No.1 Chint Road, Chint Industrial Park, North
Baixiang Town, LeQing, Zhejiang

Tel : +86-577-62877777 <http://www.chint.net>

Fax : +86-577-62875888 E-mail : chint@chint.com

Fake Product Complaint: +86-577-62789987

Product Quality Complaint: 800-8577777 400-8177777

Publish Date:2018.03



Foreword

Thanks for using NVF2G series frequency converter!

The NVF2G series is a kind of high-performance open-loop vector control frequency converter of multi-functions and low noise. The product adopts sensorless vector control technology to offer excellent control performance. It is featured with high starting torque, high reliability, good overloading capacity and convenient operation.

NVF2G series frequency converter is developed according to the GB/T 12668.2 standard. Except for electrical properties and environmental tests, it also passed electromagnetic compatibility test, such as tests of immunity to conducted interference, immunity to radiated interference, immunity to surge, immunity to rapid changed pulses, immunity to ESD and immunity to low-frequency of power supply. That further enhances the product reliability and environment adaptability. It can better meet the demands of the various drive applications.

This Operation Manual includes detailed operating descriptions and notices of NVF2G series frequency converter. In order to obtain the optimum efficiency of the product, please read the Operation Manual carefully before using. Please keep this manual on hand for your reference in future.

Product shall be subject to changes without prior notice.

■ Select frequency converter

1. T type (constant torque): load has constant torque. Torque provided by motor shall be almost irrelevant with rotational speed. That is to say in different rotational speed the torque is constant. For example: lifting equipment, conveyer belt, trolley and machines.
2. P type (fan and pump): the torque of load will be reduced at low speed. The torque of square-torque load, such as fan and water pump will be much lower at low speed. If the frequency increases to power frequency or above, needed power will increase rapidly even exceed the capacity of motor and frequency converter, so do not increase frequency facility. If frequency needs to be increased to the power frequency or above please choose frequency converter of larger capacity.
3. NVF2G series frequency converter is designed to meet the running requirement of current and parameters for 4-classes motor. If the motor is not 4-pole (such as 8-pole motor, 10-pole motor or even more), frequency converter selection does not only depend on the frequency of motor, but also depend on the current parameters.
4. Compared to general cage motors, the winding motors are more often over-current which is caused by harmonic current, so please select a frequency converter of a little larger capacity.
5. With some loads such as compressor and vibrator whose torque is fluctuant and other loads like injectors which has peak load, the frequency converter may cause error protection action, such as peak current protection. Check the current waveform and select a frequency converter whose rated current shall be larger than the Maximum current of the motor.
6. Roots blower is often used in the exhausting slot of wastewater treatment plant. Its torque characteristic can not be adjusted in 20 percent of rated speed because its output pressure is basically the same and the torque is almost constant. Select a frequency converter whose rated capacity shall be 120% of motor rated power. Speed adjusting begins at 20 percent of rated speed.
7. Compared to general motor, the rated current of deep well pump motor is higher because of its special structure. Select a frequency converter whose rated current shall be higher than the rated current of motor.
8. If the rotary inertia is larger, such as centrifugal machine, it needs larger speed-up torque and more time to accelerate. In order to avoid over-load protection, the current of motor shall be within the rated current of frequency

converter while speeding.

■ Unpacking inspection

The products have been strictly checked before shipment, but there may be some unexpected damages during the transportation. So it is suggested to check the products carefully after received. If there is anything abnormal, please contact our dealer or our company immediately.

1. Inspect the frequency converter to ensure there is no damage, rupture or deformation and no foreign objects within it. Make sure the screws are not loosened during the transportation;
2. Ensure the Operation Manual and Certificate are in the packing box;
3. Check the nameplate information and ensure the product is what you purchased;
4. Check whether there is any damage on the body, rupture, deformation, etc , presence of foreign bodies in the inverter.
5. NVF2G-110/TS4~NVF2G-315/PS4 product standard dc reactor。 DC reactor for separate packing, please check with the goods.

Safety Precautions

Safety level is divided into “Danger” and “Note” in this manual.

 **Danger:** The misuse may cause fire, severe injury, even death.

 **Note:** The misuse may cause medium or minor injury and equipment damage.

Note: “Note” grade issues may also have serious consequences. Please follow the two levels of various instructions, because they are important for your personal safety.

■ Prevent electric shock

 Danger
<ul style="list-style-type: none"> ● Never remove the cover while the frequency converter is running or powered on to avoid any injury of electric shock. ● Never start up the frequency converter while the cover is removed to avoid any injury of electric shock. ● Even if the power is OFF, do not remove the cover except wiring and regular check to avoid any injury of electric shock. ● Please wait for 10 minutes after powered off, then test the voltage between \oplus and \ominus by multimeter, it can carry out wiring or inspection until the voltage is less than 36V. ● The earth terminal must be reliably grounded. (Otherwise there may be 30V~150V induced voltage) ● The operation and inspection work must be carried out by professional personnel. ● Never operate the frequency converter with wet hands to avoid any injury of electric shock. ● Never replace fan while the frequency converter is running to avoid any injury of electric shock. ● Before wiring operation, operator must confirm the input power is completely broken; otherwise there is a risk of electric shock. ● After the change control board, it is necessary to set parameters correctly, to run; otherwise there is a risk of damage property. ● Main circuit wiring use the cable exposed part. Then, must tie with insulating tape, otherwise there is a risk of electric shock.

■ Prevent fire

 Note
<ul style="list-style-type: none"> ● Please install frequency converter on non-combustible objects and far away from combustible material to prevent fire. ● Please shut down the input power supply while frequency converter fault occurs to prevent fire caused by large current. ● Please do not connect resistors between \oplus and \ominus directly to prevent fire. ● Don't put the fuel in a nearby, otherwise there is a risk of fire. ● Don't install in containing the explosive gas environment, otherwise there is a rise of explosion.

■ Prevent damage

 Note
<ul style="list-style-type: none"> ● Applied voltage to terminals must be the voltage defined in this manual. ● Make sure the wiring of main circuit is correct. ● Make sure wiring polarity is correct. ● Don't touch Frequency converter when it is powered on or shortly after being shut down to prevent scald injury.

■ Handling and installation

 Note
<ul style="list-style-type: none"> ● Please use the appropriate tools for handling products to prevent injury. ● Do not stack the frequency converter too high. ● Make sure the installation location and object can withstand the weight of frequency converter. Install the frequency converter according to the requirements in the manual. ● If the frequency converter is damaged or short of components, please do not install it. ● Don't grab the front cover when moving the frequency converter; it should be carried with the base to avoid dropping or causing any injury. ● Do not place heavy objects on the top of frequency converter to prevent deformation. ● Make sure the direction of installation is correct. ● Make sure that there is no metal device and flammable object in the frequency converter, such as screws and paint. ● The frequency converter shall not be dropped, or suffer a violent collision. ● The switch circuit breaker should be installed at the input terminals of frequency converter to control that power on or power off.

■ Wiring

 Danger
<ul style="list-style-type: none"> ● Non-professionals are not allowed to do wiring. ● Do not add any contactor, surge absorber or resistive load on the output of frequency converter. ● Check to make sure that the correct connection between U, V, W and motor, it will determine the direction of motor rotation.

■ Running

 Danger
<ul style="list-style-type: none"> ● Check all the parameters, and make sure that startup will not damage the frequency converter. ● Don't run the frequency converter while the front cover or other parts of frequency converter are removed, and run the frequency converter according to this manual. ● Between the grid and frequency converter, you must install the isolation switch device to ensure the personal safety. ● When contact is used to power supply control, don't use contact control inverter electric up and down. ● DC reactor To defend the power influence on frequency converter, protect frequency converter and suppress high order harmonic, in the following situations, we should configure DC reactor.

- a. When the same power source node of given inverter power supply have switch type no power compensate capacitance screen or with silicon controlled phased load , the harmonic and power grid waveform gap can damage the rectification circuit.
- b. When imbalance of 3-phase power supply of frequency converter power supply more than 3%.
- c. When asked to improve the inverter input power factor above 0.93.
- d. When the inverter access large capacity transformer, the input circuit current can damage the rectification circuit. In general case, $S > 550KkVA$, or power capacity is more than ten times the inverter capacity, inverter need to configure the DC reactor.

- AC input reactor
When the power grid waveform distortion, or after configuring the DC reactor, the inverter and power between higher harmonic influence each other can't meet the requirements, can add AC input reactor. In addition, it can improve the inverter input power factor.
- AC output reactor
When the inverter to the motor connection longer than 100m, suggested that use multi-stranded cables and install suppress high-frequency oscillation of the AC output reactor. Avoid motor insulation damage, large leakage current and inverter frequent protection.
- Input EMI filter
You may select EMI filter to suppress high frequency noise jamming from the inverter power lines.
Installing the input EMI filter should be as close to the inverter.
- Output EMI filter
You may select EMI filter to suppress the output of the inverter generated noise and wire leakage current.
Installing the output EMI filter should be as close to the inverter.
- Safety ground
Inverter exist in leakage current, in order to ensure the safety inverter and motor must be grounded, grounding resistance should be less than 10 ohms. Grounding wire as short as possible.

Conductivity coefficient is determined using the table I

Table I cross-sectional area of the protection conductor

Phase conductor cross-sectional area installation S (mm ²)	Corresponding protective conductor minimum cross-sectional area Sp (mm ²)
$S \leq 16$	S
$16 < S \leq 35$	16
$35 < S$	S/2

■ Operation



Note

- Do not come close to frequency converter when the fault restart function is used to avoid anything unexpected. Because motor may automatically restart after alarm stops.
- Make sure that start signal is off before reset frequency converter alarm. Otherwise, the motor may automatically restart.
- The load should be three-phase squirrel-cage induction motor. Otherwise, the load may cause damage to the equipment.
- Never transform the frequency converter.

- Never start and stop the frequency converter by turning on/off the power.
- Never use noise filter to reduce the impact of electromagnetic interference. Otherwise, the frequency converter is likely to be affected near the use of electronic equipment.
- Reduce harmonics by applying appropriate measures. Otherwise, harmonics will damage capacitors and power generation equipment.
- Necessary parameters should be set again after initialization.
- Make sure electric and mechanical properties can bear high-speed operation.
- Inspection and commissioning should be carried out after the frequency converter is stored or not used more than six months.
- Frequent start-stop, should through the terminal to start-stop control of frequency converter, it is strictly prohibited in the use of frequency converter input side contactor switch device with frequent start-stop operation directly; otherwise it will result in equipment damage.

■ Emergency Stop



Note

- If frequency converter fails, in order to prevent machinery or equipment from risk, please install safety device such as emergency brake.

■ Maintenance



Note

- Remove all cables on the terminal before testing insulation resistance of external circuit by using megohm.
- Test the control circuit by using the high impedance section of multimeter.
- Only test the main loop carefully when measuring the insulation resistance. Please do not test the control circuit by using megohm. Do not carry out pressure test to the frequency converter. (The main circuit of frequency converter is made up of semi-conductors, possible damages may be caused if pressure test is carried out.)

■ Treatment after end-of-life



Note

- Follow the industrial waste treatment regulations.

Content

Chapter 1 Overview.....	1
1.1 Nameplate information.....	1
1.2 Model description.....	1
1.3 Model specification of NVF2Gseries frequency converter.....	2
1.4 Technical specification.....	3
1.5 The external appearance of NVF2Gseries frequency converter.....	4
Chapter 2 Installation.....	8
2.1 Installation requirements.....	8
2.2 Operating environment.....	9
Chapter 3 Wiring.....	11
3.1 Wiring description.....	11
3.2 Terminal configuration.....	12
3.3 Wiring requirements.....	15
Chapter 4 Operation.....	18
4.1 Operation panel.....	18
4.2 Change parameters.....	19
4.3 LED display description.....	19
4.4 Indicator lamp description.....	20
Chapter 5 List of parameter.....	22
Chapter 6 Detailed introductions to Parameter.....	38
Chapter 7 Fault check and handling.....	76
7.1 List of Fault and Warning Messages.....	76
7.2 Common fault and solutions.....	78
Chapter 8 Maintenance and Inspection.....	79
8.1 Daily maintenance.....	79
8.2 Periodic maintenance.....	79
8.3 Wearing parts replacement.....	80
8.4 Frequency converter storage.....	80
Chapter 9 RS485 Communication.....	81
9.1 Protocol.....	81
9.2 Application.....	81

9.3 Bus Architecture.....	81
9.4 Protocol Description.....	81
9.5 Modbus message frame.....	82
9.6 Command code and communications data.....	84
9.7 Frame error check.....	88
9.8 Communication address description.....	89
9.9 Wiring description.....	92
Appendix A Optional devices.....	93
Appendix B Frequency converter Maintenance.....	96
Appendix C Quality commitment.....	98

Chapter 1 Overview

1.1 Nameplate information

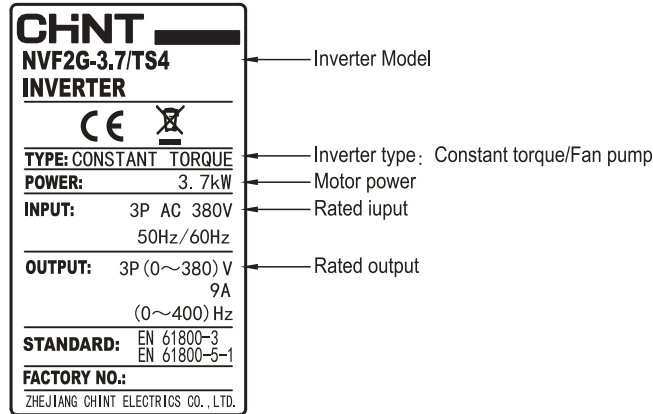
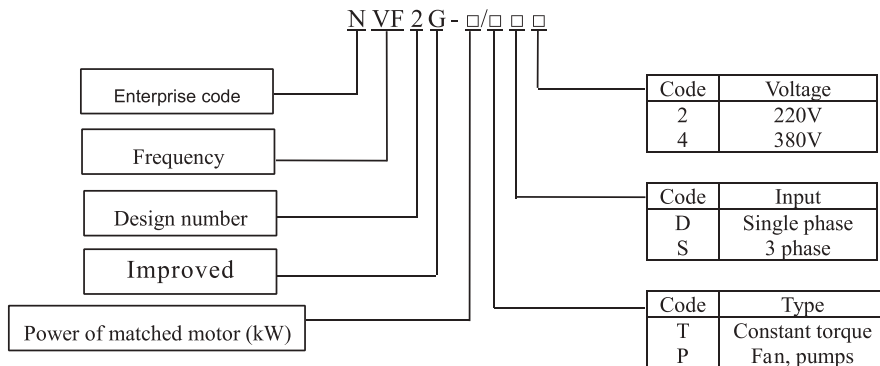

Fig 1.1 Nameplate

1.2 Model description



1.3 Model specification of NVF2G series frequency converter

Power supply	Model	Power capacity kVA	Input/output Cable	Rated output current (A)	Max. Power of matched motor (kW)	Line switch breaker QF (A)
(3 phase) AC 380V	NVF2G-1.5/T(P)S4	3	1.5	3.7	1.5	6
	NVF2G-2.2/T(P)S4	4.2	2.5	5.0	2.2	10
	NVF2G-3.7/T(P)S4	7.6	4	9.0	3.7	16
	NVF2G-5.5/PS4	9.9	4	11	5.5	20
	NVF2G-5.5/TS4	9.9	4	13	5.5	20
	NVF2G-7.5/T(P)S4	13	6	17	7.5	25
	NVF2G-11/PS4	18	10	22	11	40
	NVF2G-11/TS4	18	10	25	11	40
	NVF2G-15/T(P)S4	25	10	32	15	50
	NVF2G-18.5/T(P)S4	29	16	37	18.5	63
	NVF2G-22/T(P)S4	34	16	45	22	63
	NVF2G-30/T(P)S4	46	25	60	30	100
	NVF2G-37/T(P)S4	57	25	75	37	125
	NVF2G-45/T(P)S4	69	35	90	45	160
	NVF2G-55/T(P)S4	85	35	110	55	160
	NVF2G-75/PS4	114	50	140	75	250
	NVF2G-75/TS4	114	50	150	75	250
	NVF2G-90/T(P)S4	133	70	176	90	250
	NVF2G-110/T(P)S4	160	120	210	110	315
	NVF2G-132/T(P)S4	195	120	253	132	400
	NVF2G-160/T(P)S4	236	120	300	160	630
	NVF2G-185/T(P)S4	267	240	340	185	630
	NVF2G-200/T(P)S4	289	240	380	200	630
	NVF2G-220/T(P)S4	305	150*2	420	220	630
NVF2G-245/T(P)S4	350	150*2	470	245	800	
NVF2G-280/T(P)S4	403	185*2	520	280	800	
NVF2G-315/PS4	464	185*2	600	315	1000	
NVF2G-315/TS4	420	240*2	600	315	1000	
NVF2G-355/T(P)S4	420	240*2	640	355	1000	
NVF2G-400T(P)S4	460	300*2	690	400	1000	

Note: Max. Power of matched motor refers to the maximum power driven by frequency converter, 4-pole as standard.

1.4 Technical specification

Input and output character	Input voltage range	(380±57) V
	Input frequency range	47Hz~63Hz
	Output voltage range	0~Rated input voltage
	Output frequency range	0Hz~400Hz(Fan, Pump: 0Hz~120Hz)
Peripheral interface character	Programmable digital inputs	6 inputs
	Programmable analog inputs	AI1: 0V~10V; AI2: 0V~10V or 0mA/4mA~20mA
	Open collector output	1 output
	Relay output	2 outputs
	Analog output	2 output, 0V~10V or (0/4~20)mA
	RS485 interface	1 interface, support Modbus protocol
Technical performance	Control mode	vector control without PG, V / F control
	Over-load ability	Constant torque: 150% of rated current:60s; Fan and Pump: 120% of rated current: 60s
	Startup torque	Vector control without PG: 0.5Hz/150% (rated torque)
	Speed adjusting rate	Vector control without PG: 1:100; V/F: 1:50
	Speed control accuracy	Vector control without PG: ±0.5% of max. speed
	Carrier frequency	0.5kHz~15.0kHz
Functions	Frequency settings method	Digital, analog setpoint, serial communicate setpoint, FF setpoint, PID setpoint
	Control function	Forward, reverse PID control
	Muti-speed Control function	Eight period of speed control
	Dedicated function	Dedicated frequency control for textile machine
	Speed tracking and re-start function	Realize smoothing start-up for the rotating motor without impact.
	Automatic voltage regulator function	When the grid voltage changes, the equipment automatically maintains a constant output voltage
Others	Fault protection	Over-current, over-voltage, under-voltage, phase loss, over-temperature, overload, PID etc.
	Protection class	IP20
	Cooling mode	Forced air convection cooling
	Braking unit	NVF2G-1.5/PS4 ~ NVF2G-22/PS4: standard built in, NVF2G-22/TS4 ~ NVF2G-110/PS4: optional built in; NVF2G-110/TS4 and above: optional built outside
	External dc reactor	NVF2G-45/TS4~110/PS4 (optional) NVF2G-110/TS4~315/PS4 (The standard)
	Built-in dc reactor	NVF2G-315/TS4~400/TS4 (The standard)

1.5 The external appearance of NVF2Gseries frequency converter

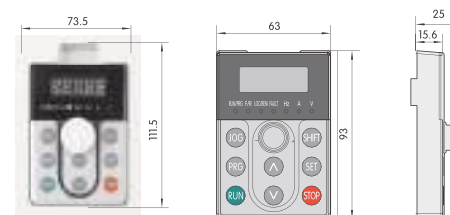

The size of the opening hole of the display box is 73.5×111.5

Fig 1.2 Outline of display panel

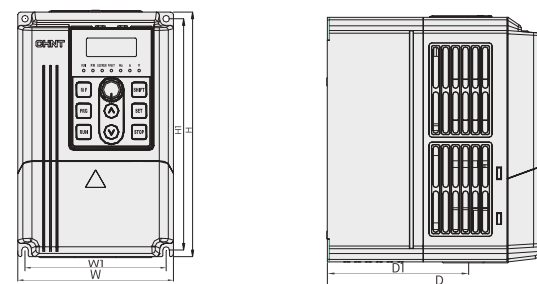

Fig1.3 Frequency converter appearance (NVF2G-1.5/PS4~11/PS4)

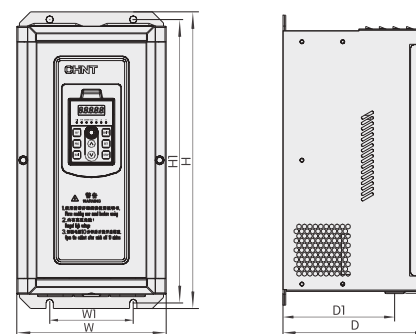

Fig1.4 Frequency converter appearance (NVF2G-11/TS4~22/PS4)

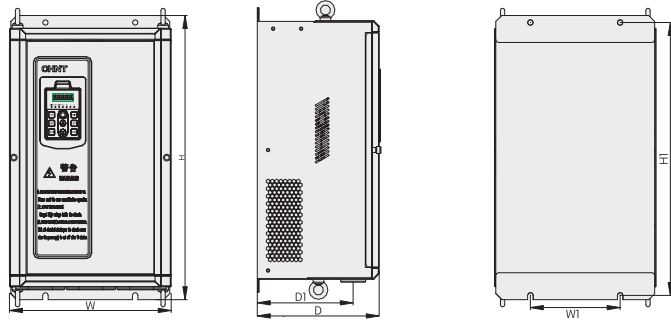

Fig1.5 Frequency converter appearance (NVF2G-22/TS4~75/PS4)

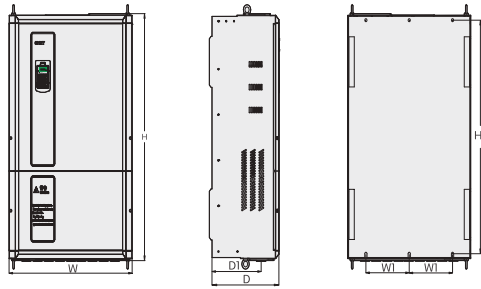

Fig1.6 Frequency converter appearance (NVF2G-75/TS4~315/PS4)

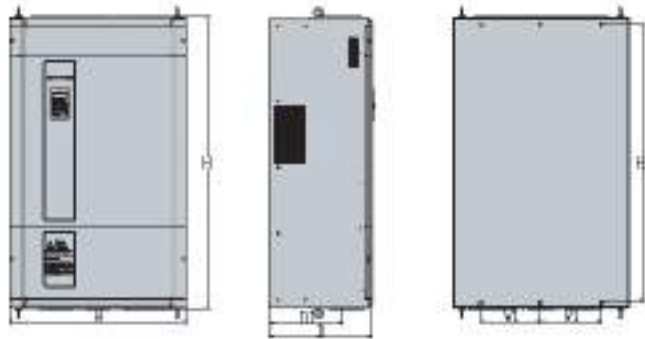

Fig1.7 Frequency converter appearance (NVF2G-315/TS4 ~ NVF2G-400/TS4)

External dimensions of NVF2Gseries frequency converter

Product Spec.	W	H	D	W1	H1	D1	Weight (kg)	Remark
NVF2G-1.5/PS4	118	187	173	107	175	110	2.4	Fig1.3
NVF2G-1.5/TS4 (2.2/PS4)								
NVF2G-2.2/TS4 (3.7/PS4)								
NVF2G-3.7/TS4 (5.5/PS4)								
NVF2G-5.5/TS4 (7.5/PS4)	155	247	189	140	232	125	3.6	Fig1.3
NVF2G-7.5TS4 (11/PS4)								
NVF2G-11/TS4 (15/PS4)	191	378	183	90	362	129	10.5	Fig1.4
NVF2G-15/TS4 (18.5/PS4)	215	426	213	120	407	164	15	Fig1.4
NVF2G-18.5/TS4 (22/PS4)								
NVF2G-22/TS4 (30/PS4)	300	527	230	166.6	506	179	26.5	Fig1.5
NVF2G-30/TS4 (37/PS4)								
NVF2G-37/TS4 (45/PS4)								
NVF2G-45/TS4 (55/PS4)	352	603	257	240	577	197.5	34.4	Fig1.5
NVF2G-55/TS4 (75/PS4)								
NVF2G-75/TS4 (90/PS4)	406	631	272	126	600	224	58	Fig1.6
NVF2G-90/TS4 (110/PS4)								
NVF2G-110/TS4 (132/PS4)	470	807	352	150	769	226.5	108	Fig1.6
NVF2G-132/TS4 (160/PS4)								

Product Spec.	W	H	D	W1	H1	D1	Weight (kg)	Remark
NVF2G-160/TS4 (185/PS4)	540	892	390	180	848	256	121	Fig1.6
NVF2G-185/TS4 (200/PS4)								
NVF2G-200/TS4 (220/PS4)								
NVF2G-220/TS4 (245/PS4)	710	1020	386	250	978	284	171.5	Fig1.6
NVF2G-245/TS4 (280/PS4)								
NVF2G-280/TS4 (315/PS4)								
NVF2G-315/TS4 (355/PS4)	734	1200	426	250	1152	313	280	Fig1.7
NVF2G-355/TS4 (400/PS4)								
NVF2G-400/TS4								

Chapter 2 Installation

This chapter provides installation requirements and environment, please read this chapter carefully before using the frequency converter.

2.1 Installation requirements

2.1.1 Frequency converter is a precise electronic product, so the ambient conditions will affect its service life. Please check whether the ambient conditions of the frequency converter match the requirements of "Operating environment" in this chapter. If not, please do not install the product; otherwise, it will be damaged.

2.1.2 Plastic parts are used in the frequency converter, so please do not use excessive force to remove its cover, and it shall be installed carefully to avoid damage.

2.1.3 If ambient permits, please install the back or heat dissipation plate outside the cabinet to achieve good cooling effect.

2.1.4 Frequency converter shall be installed in a clean location or in a closed cabinet which can prevent floating material.

2.1.5 Frequency converter must be installed vertically and securely on the installation board or wall with screws.

2.1.6 Pay attention to the cooling method when the frequency converter is installed in electrical control cabinet. If more than two frequency converters are installed together in one cabinet, please pay attention to the correct installation positions to make sure the ambient temperature is within permissible value. If installation position is not ventilated enough, the cooling effect will be sharply reduced.

2.1.7 Frequency converter shall be installed on non-combustible materials, such as iron plates, wall, and please leave enough space around it, as shown in follow fig.

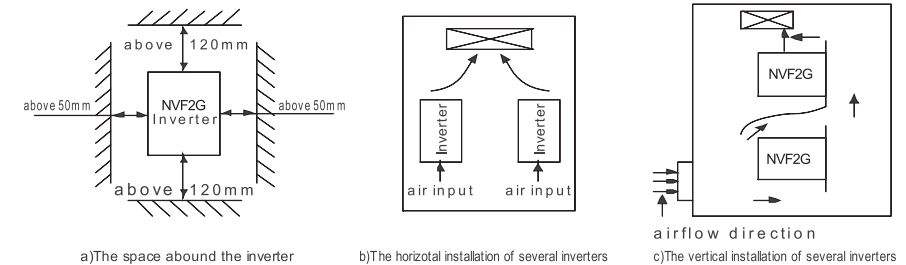

Fig 2.1 Installation

2.2 Operating environment

2.2.1 Temperature

Operating temperature: -10°C to $+40^{\circ}\text{C}$, above 40°C , the frequency converter has to derate by 1% for every additional 1°C .

2.2.2 Humidity

Air relative humidity $\leq 95\%$, no condensation is allowed.

2.2.3 Altitude

The frequency converter can run at rated power if installation site is less than 1000m above the sea level. If the altitude is more than 1000m, frequency converter has to derate. Figure 2.2 curve for the rated current of the inverter and altitude.

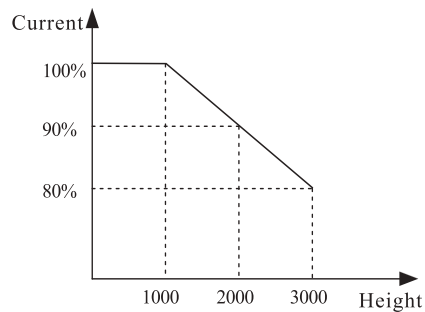

Fig 2.2 Curve rated current of the inverter and altitude

2.2.4 Shock and vibration

The frequency converter can not bear falling to the ground or sudden impact. Do not install the frequency converter in a place where shacked frequently.

2.2.5 Electromagnetic radiation

The Frequency converter should be kept away from the electromagnetic radiation source.

2.2.6 Protection of water and water vapor

The frequency converter should be kept away from dripping water or condensation.

2.2.7 Air pollution

The frequency converter should be kept away from contaminative air, such as

corrosive gas and conductive dust.

2.2.8 Installation and storage

The frequency converter should be kept away from direct sunlight, oil mist and vibration environment.

2.2.9 Pollution degree: 3

Chapter 3 Wiring

This chapter provides wiring instructions, please read this chapter carefully before using the frequency converter.

3.1 Wiring description

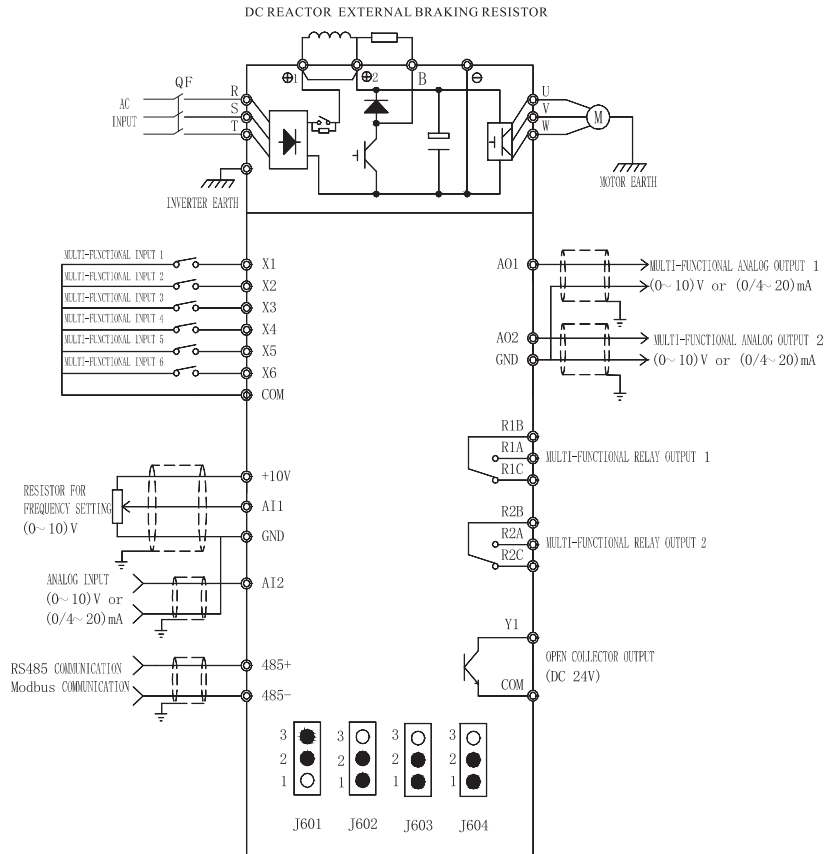

Fig. 3.1 Wiring diagram (NVF2G-1.5/PS4 ~ NVF2G-400/TS4)

Note:

- J601(A11 terminal): 1 and 2: 0V~10V analog input voltage of A11. 2 and 3: panel potentiometer input.
- J602(A12 terminal): 1 and 2: 0V~10V analog voltage input. 2 and 3: 0/4mA~20mA analog current input.
- J603(AO1 terminal): 1 and 2: 0V~10V analog voltage output. 2 and 3: 0/4mA~20mA analog current output.
- J604(AO2 terminal): 1 and 2: 0V~10V analog voltage output. 2 and 3: 0/4mA~20mA analog current output.

3.2 Terminal configuration

3.2.1 Arrangement of main circuit terminals

(1) 3 phase 380V (NVF2G-1.5/PS4 ~ 11/PS4)



(2) 3 phase 380V (NVF2G-11/TS4 ~ 22/PS4)

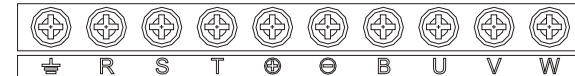

(3) 3 phase 380V (NVF2G-22/TS4 ~ 75/PS4)

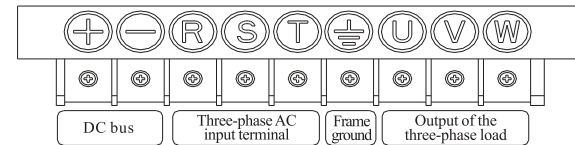

(4) 3 phase 380V (NVF2G-75/TS4 ~ 110/PS4)

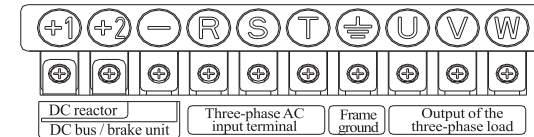

(5) 3 phase 380V (NVF2G-110/TS4 ~ 160/PS4)

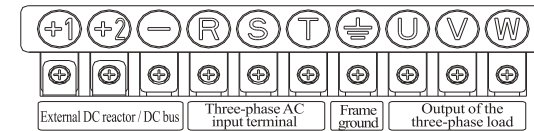

(6) 3 phase 380V (NVF2G-160/TS4 ~ 315/PS4)

Lower end of the connection port

Wiring the upper mouth

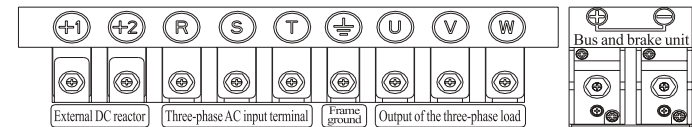

(7) 3 phase 380V (NVF2G-315/TS4 ~ 400/TS4)

Wiring the upper mouth

Lower end of the connection port



3.2.2 Description of main circuit terminals

Terminal mark	Name and description
R、S、T	AC input terminals, connect to Power Supply, AC380V 47Hz~63Hz
⊕、⊖	DC input terminals, connect to exterior braking unit
+1、+2	Connect to external DC reactor
⊕、B	Connect to brake resistor
U、V、W	AC output terminal
	Earth terminal

3.3.3 Wiring description of main circuit

- 1) It is better to use the pressure wire terminal with insulated pipes for power supply and electrical wiring.
- 2) Never connect power line with other terminals except R.S.T terminals. Otherwise the frequency converter will be damaged.
- 3) Please clean the fragment end of a thread to avoid abnormal, failure and fault to the frequency converter. Punch in the console carefully not to make powder and other debris into the frequency converter.
- 4) Appropriate sizes and specifications of wires should be selected to ensure a voltage drop of 2% or less. When the wiring between the frequency converter and motor is long, especially in low frequency output, the output torque will decrease due to voltage drop of main circuit cables.
- 5) When the wiring between the frequency converter and the motor exceeds 100 meters, the leakage current will be much higher due to parasitic capacitance effects of long cable, and at the same time output reactor compensation in output terminal needs to be added to avoid the damage to insulation of motor.
- 6) If you need emergency braking, you are suggested to select braking resistor which is connected between terminal ⊕ and B.
- 7) +1、+2 terminal for external dc reactor terminals, +1、+2 terminal dc reactor in series.
- 8) You are suggested to install noise filter on the input and output-side of the frequency converter to reduce harmonics.
- 9) Capacitor and surge suppressor shall never be connected to output terminals of the frequency converter. It will cause fault or damage of frequency converter.
- 10) Please wait for 10 minutes after powered off, then test the voltage between ⊕ and ⊖ by multimeter, you can carry out wiring or inspection until the voltage is less

than 36V.

11) Earth terminal must be grounded.

▲ Because of Leakage current, frequency converter and motor must be grounded to prevent electric shock.

▲ Choose independent earth terminal (Do not use chassis or screws on the shell for replacement).

▲ The grounding wire must be as short as possible. The diameter of grounding cable must be equal to or greater than the standard diameter shown in the following table.

Grounding wire standard

Cross-sectional area of power cable (mm ²)	Cross-sectional area of grounding cable (mm ²)
$S \leq 16$	S
$16 < S \leq 35$	16
$35 < S$	S/2

Note: (1) Make sure that the mark of brake unit is the same to the terminals (⊕, ⊖) to avoid damaging the frequency converter. (2) The wire between brake resistor and brake unit shall be less than 5 meters or 10 meters with twist pair cable.

3.2.4 Arrangement of control circuit terminals

Three phase 380V (NVF2G-1.5/PS4~NVF2G-400/PS4)

485+	485-	X1	X2	X3	X4	X5	X6	Y1	COM	R2A	R2B	R2C
+10V	AI2	AI1	GND	AO1	AO2	GND	COM	+24V	R1A	R1B	R1C	

3.2.5 Description of control circuit terminals

Terminal mark	Name	Description
R1A, R1B, R1C R2A, R2B, R2C	Relay output	RA, RB is NO; RB, RC is NC, set by F6.00 F6.01. Default value is fault/run signal.
Y1, COM	Open-collector output	Set by F6.00. Default value is forward run
485+, 485-	Serial communication	RS485 serial communication terminal
+10V	Power for setting frequency	Connect to potentiometer (4.7K-10K) with AI1, AI2, GND
AI1, GND	Analog signal input	Connect to potentiometer or 0V-10V signal, as signal of frequency given or PID given or PID feedback
AI2, GND	Analog signal input	Input a signal of DC 0V-10V/0(4)mA -20mA, as signal of frequency given or PID given, or PID feedback

Terminal mark	Name	Description
AO1、GND	Analog signal output	Voltage meter (DC 0V-10V/0(4)mA -20mA) connects between AO1 and GND to get signal of frequency, output current and output voltage
AO2、GND	Analog signal output	Voltage meter (DC 0V-10V/0(4)mA -20mA) connects between AO2 and GND to get signal of frequency, output current, and output voltage
X1	Multi-function input terminal 1	Default: forward run
X2	Multi-function input terminal 2	Default: reverse run
X3	Multi-function input terminal 3	Default: forward JOG
X4	Multi-function input terminal 4	Default: reverse JOG
X5	Multi-function input terminal 5	Default: fault reset
X6	Multi-function input terminal 6	Default: external fault input
COM	Public earth for multi-function input terminal	Public earth for X1~X6, coupled with X1~X6
24V、COM	Auxiliary Power 24V output	DC 24V output(≤50mA)

Note:

- 1) Terminal COM is public end for X1-X6 digital control signals (multi-function input terminal); and terminal GND is public end for AI1, AI2, AO terminals, so please do not connect them to the earth.
- 2) Shielded twisted pair should be used in control circuit, and cabling must be separate from the main circuit, power circuit.
- 3) Control circuit is suggested to use the cable of 0.75 mm².
- 4) Never import strong electricity to the control circuit; otherwise the converter will be damaged.

3.3 Wiring requirements

- 3.2.1 The power line and control line shall be arranged separately, such as using separate ducts. If the control line has to be crossed with power line, they shall be vertically cabled.
- 3.2.2 Using shielded or twisted pair wire to connect the control circuit shall ensure that the unshield part is as short as possible. If permitted, it is better to use cable sleeve.
- 3.2.3 Testing Instrument and sensor cable shall use shielded twisted cable and earth with metal cable clamp.
- 3.2.4 Earth line of frequency converter and motors shall be connected to the same point.

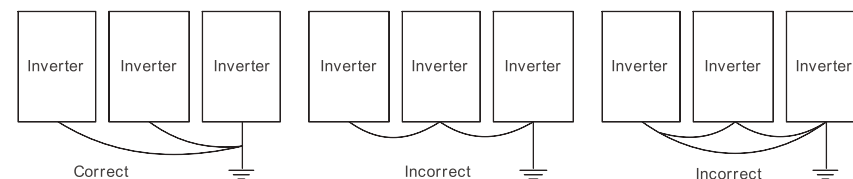

Fig 3.2 Grounding diagram

3.3.5 Wiring compliance with EMC the standard

In order to ensure all electric devices in the same system to work smoothly, this section, based on EMC features of frequency converter, introduces EMC installation process in several aspects of application (noise control, site wiring, grounding, leakage current and power supply filter).

■ Noise control

All the connections to the control terminals must use shielded wires, and the shield layer of wire must ground near the wire entrance of frequency converter. The ground mode is 360 degree annular connection formed by cable clips, it is strictly prohibitive to connect the twisted shielding layer to the ground of frequency converter, which greatly decreases or loses the shielding effect.

Connect frequency converter and motor with the shielded wire or the separated cable tray. One side of shield layer of shielded wire or metal cover of separated cable tray should be connected to the ground, and the other side should be connected to the motor cover, installing an EMC filter can reduce the electromagnetic noise greatly.

■ Site wiring

Power supply wiring: the power should be separately supplied from electrical transformer. Normally it is 5 core wires, three of which are fire wires, one of which is the neutral wire, and one of which is the ground wire. It is strictly prohibitive to use the same line to be both the neutral wire and ground wire.

Wire arrangement inside control cabinet: there are signal wire (light current) and power cable (strong current) in the cabinet. For the frequency converter, the power cables are categorized into input cable and output cable. Signal wires can be easily disturbed by power cables to cause malfunction of the equipment. Therefore wiring, signal cables and power cables should be arranged in different areas. It is strictly prohibitive to arrange them in parallel or interlacement at a close distance (less than 20cm) or tie them together. If signal wires have to cross the power cables, they should be arranged in Vertical. Power input and output cables should not either be arranged in interlacement or tied together, especially when installed the EMC filter. Otherwise the distributed capacitances of its input and output power cable can be coupling each other to make the EMC filter out of function.

■ Grounding

Frequency converter must be grounded safely when in operation. Grounding enjoys priority in all EMC methods because it does not only ensure the safety of equipment

and persons, but also is the simplest, most effective and lowest cost solution for EMC problems.

Grounding has three categories: special pole grounding, common pole grounding and series-wound grounding. Different control system should use special pole grounding, and different devices in the same control system should use common pole grounding, and different devices connected by same power cable should use series-wound grounding.

■ Leakage current

Leakage current includes line-to-line leakage current and over-ground leakage current, its value depends on distributed capacitances and carrier frequency of frequency converter. The over-ground leakage current, which is the current passing through the common ground wire, can not only flow into frequency converter system but also other devices. It also can cause leakage current circuit breaker, relay or other devices malfunction. The value of line-to-line leakage current, which means the leakage current passing through distributed capacitors of input output wire, depends on the carrier frequency of frequency converter, the length and section areas of motor cables. The higher carrier frequency of frequency converter, the longer of the motor cable and/or the bigger cable section area, the larger leakage current will occur.

Countermeasure: decreasing the carrier frequency can effectively decrease the leakage current. In the case of motor cable is relatively long (longer than 50m), it is necessary to install AC reactor or sinusoidal wave filter at output side, and when it is even longer, it is necessary to install one reactor at every certain distance.

■ Noise filter

Noise filter has a great effect of electromagnetic decoupling, so it is preferred for customer to install it.

For frequency converter, noise filter has following categories:

1. Noise filter installed at the input side of frequency converter;
2. Install noise isolation for other equipment by means of isolation transformer or power filter.

Chapter 4 Operation

This chapter provides operation method, please read the contents carefully before using the Frequency converter.

4.1 Operation panel



Fig. 4.1 Appearance of display panel

Operation panel is a Human-Machine Interface, and consists of key and display part, key is provided for you to input order, while display part is for displaying parameter and current running status. Detailed descriptions are shown as follows:

Symbol	Name	Function
JOG	Forward and reverse switch/JOG key	JOG run by press this key, if F7.03=1, change running direction
PRG	Programme Key	Press this key to enter function setting status, modify finished, press it to exit
RUN	Run key	Press it to run frequency converter, invalid when controlled by external terminal
▲	Up key	In programming mode, increase functional code and parameter. In running or standby mode, increase running frequency
▼	Down key	In programming mode, decrease functional code and parameter. In running or standby mode, decrease running frequency
SHIFT	Shift key	In programming mode, shift the cursor. In running or standby mode sequence displays the operating frequency, bus voltage,

Symbol	Name	Function
		output voltage, output current, speed, output power, etc
SET	Set key	In programming mode, press it to confirm function code, after parameter modified press it again to save the data modified
STOP	Stop/Reset Key	Press it to stop Frequency converter (affected by F7.04). After alarm press it to reset

4.2 Change parameters

If you need to modify the parameters, firstly, enter the function code which needs to be modified. And then reset the parameter. Detailed steps are shown as follows:

Order	Operation	Description
1	Press PRG key	Display F0, enter parameter group.
2	Press ▲ ▼ key	Shift to the parameter group (FX) you need.
3	Press SET key	Display FX-XX, enter parameter modification code
4	Press ▲ ▼ key	Shift to the function code you need to modify.
5	Press SET key	Display XXXX, enter modify status.
6	Press ▲ ▼ key	Reset parameters according to the need
7	Press SET key	Store the data, and then display F-XXX
8	Press PRG key	Exit setting mode and return to standby / run status.

4.3 LED display description

The relationship between characters displayed by LED and characters/numbers are as follows:

LED display	Meanings	LED display	Meanings	LED display	Meanings	LED display	Meanings
	0		A		I		S
	1		b		J		T
	2		C		L		t
	3		c		N		U

LED display	Meanings	LED display	Meanings	LED display	Meanings	LED display	Meanings
	4		d		n		v
	5		E		O		y
	6		F		o		-
	7		G		P		8.
	8		H		q		.
	9		h		r		:

4.4 Indicator lamp description

Symbol of Indicator	Name	Meaning	
Status indicator	RUN/PRG	Off	Frequency converter in stop status
		Flash	frequency converter in parameter identification status
		On	Frequency converter in running status
	F/R	Off	Frequency converter in forward run
		On	Frequency converter in reverse run
	LOC/REM	Off	Run command channel is keyboard
		Flash	Run command channel is terminal
		On	Run command channel is communication
	FAULT	Off	Frequency converter in normal status
Flash		Frequency converter in fault status	
Unit indicator	Hz	On	Parameter displayed is running frequency
		Flash	Parameter displayed is frequency setpoint
	A	On	Parameter displayed is real output current

Symbol of Indicator		Name	Meaning
V	On		Parameter displayed is DC bus voltage
	Flash		Parameter displayed is output voltage
Hz + A	On		Parameter displayed is rotational speed
A + V	On		Parameter displayed is output power
	Flash		Parameter displayed is output torque

Chapter 5 List of parameter

NVF2Gseries frequency converter parameters are divided into 15 groups, F0~FE, each group includes several parameters. Parameter has three level menus, eg. "F8.08" indicates F8 group and No.8 parameter.

In order to set parameter easily, parameter group number corresponds to the first menu, parameter number corresponds to the second menus, parameters corresponding to third menus.

1. Item meanings in parameter list:

“Para. No.” Indicates the relevant parameter number

“Name” Indicates the relevant name of parameter, give a short description

“Description” Lists the possible values of a parameter or gives a short discription

“Range”Indicates the Min. and Max. value to which the parameter can be set

“Unit” Indicates the unit of measure applicable to the parameter values. Such as: V, A, °C, Ohm, mH, rpm, %, bps, Hz, kHz, ms, s, min, h, kh, kW, Nm, /(no unit)

“Default” Indicates the factory settings

“Attribute (Attr.)” Indicates when the parameter can be changed (Allow to change or not and changing condition)

“○”: Can be changed in running /stop status

“◎”: Can not be changed in running status

“●”: Read-only parameter, can not be changed in any status

(Parameter’s property has been antomatic checked to avoid error modification).

“No.” indicates the order of parameter in the whole arrangement of the series number and it also means the register address in communication.

2. "Parameter binary is decimal (DEC). If it adopts hexadecimal (HEX), every bit of parameter is independent. Some bit can adopt hexadecimal(0~F).

3. "Default value" is the value after refreshing caused by restoring the factory parameter. But actually parameters and records will not be refreshed.

4. Frequency converter provides user password in order to protect the parameter more effectively. Setting method is shown in the description of F7.00

5. User password also conforms to the above regulation while modifying parameter by serial communication.

List of parameters:

Para.No.	Name	Default	Range	Unit	Attr.	Description	No.
F0 Basic Function group							
F0.00	Speed control mode	Set by motor	0~1	/	◎	0: Sensorless vector control 1: V/F control	0
F0.01	Run command channel	0	0~2	/	◎	0: Panel control 1: Terminal control 2: Communication control	1
F0.02	Keyboard and terminal UP/DOWN setting	0	0~3	/	○	0: Valid, save parameter when powered off 1: Valid, not save parameter when powered off 2: Reserved 3: Reserved	2
F0.03	Selection of freq. setpoint	0	0~6	/	○	0: Panel setpoint (F0.07) 1: AI1 setpoint 2: AI2 setpoint 3: AI1+ AI2 setpoint 4: FF setpoint 5: PID setpoint 6: Communication setpoint	3
F0.04	Max. output frequency	50.00Hz	10.00~400.00	Hz	◎	10.00Hz~400.00Hz	4
F0.05	Upper running freq. limit	50.00Hz	F0.06~F0.04	Hz	○	F0.06~F0.04 (max. freq.)	5
F0.06	Lower running freq. limit	0.00Hz	0.00~F0.05	Hz	○	0.00Hz~F0.05 (Running freq. upper limit)	6
F0.07	Pannel freq. setpoint	50.00Hz	0.00~F0.04	Hz	○	0.00 Hz~F0.04 (max. freq.)	7
F0.08	Acc. time 1	Set by motor	0.1~3600.0	s	○	0.1s~3600.0s	8
F0.09	Dec. time 1	Set by motor	0.1~3600.0	s	○	0.1s~3600.0s	9
F0.10	Selection of running direction	0	0~2	/	◎	0: Default direction; 1: Reverse; 2: Disable reverse	10
F0.11	Carrier freq. setpoint	Set by motor	0.5~15.0	kHz	○	0.5kHz~15.0kHz	11

Para.No.	Name	Default	Range	Unit	Attr.	Description	No.
F0.12	Motor parameter automatically identification	0	0~2	/	◎	0: No operation 1: Comprehensive identification 2: Static identification	12
F0.13	Parameter initialization	0	0~2	/	◎	0: Disabled 1: Reset to default values 2: Clear all fault records	13
F0.14	Auto voltage regulation	2	0~2	/	○	0: Invalid 1: Valid all time 2: Invalid at slow down	14
F1 Start/stop control group							
F1.00	Motor start method	0	0~2	/	◎	0: Direct start 1: DC braking start 2: Flying start	15
F1.01	Start frequency of direct start	0.00	0.00~10.00	Hz	○	0.00Hz~10.00Hz	16
F1.02	Hold time of start frequency	0.0	0.0~50.0	s	○	0.0s~50.0s	17
F1.03	DC braking current before start	0.0	0.0~150.0	%	○	0.0%~150.0%	18
F1.04	DC braking duration before start	0.0	0.0~50.0	s	○	0.0s~50.0s	19
F1.05	Motor stop method	0	0~1	/	○	0: Ramp-down stop 1: Electrical stop	20
F1.06	DC braking start frequency at stop	0.00	0.00~F0.04	Hz	○	0.00Hz~F0.04(max. freq.)	21
F1.07	DC braking waiting time at stop	0.0	0.0~50.0	s	○	0.0s~50.0s	22
F1.08	DC braking current at stop	0.0	0.0~150.0	%	○	0.0%~150.0%	23
F1.09	DC braking duration at stop	0.0	0.0~50.0	s	○	0.0s~50.0s	24
F1.10	Deadband time Of Forward / reverse	0.0	0.0~3600.0	s	○	0.0s~3600.0s	25
F1.11	Protect action when power is on	0	0~1	/	○	0:Command invalid when power is on 1: Command valid when power is on	26
F1.12	Reversed	/	/	/	○	/	27

F2 Motor Parameter group

Para.No.	Name	Default	Range	Unit	Attr.	Description	No.
F2.00	Frequency converter type	Set by motor	0~1	/	◎	0: T type 1: P type	28
F2.01	Motor rated power	Set by motor	0.4~900.0	kW	◎	0.4kW~900.0kW	29
F2.02	Motor rated freq.	50.00Hz	0.01~F0.04	Hz	◎	0.01Hz~F0.04(max. freq.)	30
F2.03	Motor rated rotational speed	Set by motor	0~36000	rpm	◎	0rpm~36000rpm	31
F2.04	Motor rated voltage	Set by motor	0~460	V	◎	0V~460V	32
F2.05	Motor rated current	Set by motor	0.1~2000.0	A	◎	0.1A~2000.0A	33
F2.06	Stator resistance	Set by motor	0.001~65.535	Ω	○	0.001Ω~65.535Ω	34
F2.07	Rotor resistance	Set by motor	0.001~65.535	Ω	○	0.001Ω~65.535Ω	35
F2.08	Stator/ Rotor inductance	Set by motor	0.1~6553.5	mH	○	0.1mH~6553.5mH	36
F2.09	Mutual inductance of stator and rotor	Set by motor	0.1~6553.5	mH	○	0.1mH~6553.5mH	37
F2.10	Current without load	Set by motor	0.01~655.35	A	○	0.01A~655.35A	38
F3 vector control group							
F3.00	Proportional gain 1 of speed controller	20	0~100	/	○	0~100	39
F3.01	Integration time 1 of speed controller	0.50	0.01~10.00	s	○	0.01s~10.00s	40
F3.02	Low switching frequency	5.00	0.00~F3.05	Hz	○	0.00Hz~F3.05	41
F3.03	Proportional gain 2 of speed controller	25	0~100	/	○	0~100	42
F3.04	Integration time 2 of speed controller	1.00	0.01s~10.00	s	○	0.01s~10.00s	43
F3.05	High switching frequency	10.00	F3.02~	Hz	○	F3.02 ~ F0.04(max. frequency)	44

Para.No.	Name	Default	Range	Unit	Attr.	Description	No.
			F0.04				
F3.06	Slip compensation factor for vector control	100	50~200	%	○	50%~200%	45
F3.07	Torque upper limit setpoint	150.0	0.0~200.0	%	○	0.0% ~ 200.0% (frequency converter rated current)	46
F4 V/F control group							
F4.00	V/F cure type	0	0~1	/	◎	0: Linear V/F 1: Quadratic V/F (parabolic V/F)	47
F4.01	Torque boost	0.0	0.0~30.0	%	○	0.0%:(auto) 0.1%~30.0%	48
F4.02	Boost end torque	20.0	0.0~50.0	%	◎	0.0% ~ 50.0% (relative to rated motor frequency)	49
F4.03	V/F Slip compensation	100	0.0~200.0	%	○	0.0%~200.0%	50
F4.04	Energy saving control	0	0~1	/	◎	0: Disabled 1: Enabled	51
F4.05	Reversed	/	/	/	●	/	52
F5 Input terminals group							
F5.00	Function of X1	1	0~25	/	◎	0: No function	53
F5.01	Function of X2	2	0~25	/	◎	1: Forward run 2: Reverse run	54
F5.02	Function of X3	4	0~25	/	◎	3: Three-wire operation ctrl.	55
F5.03	Function of X4	5	0~25	/	◎	4: Forward JOG	56
F5.04	Function of X5	7	0~25	/	◎	5: Reverse JOG 6: Electrical stop	57
F5.05	Function of X6	8	0~25	/	◎	7: Fault reset 8: External fault input 9: Up command 10: Down command 11: Clear freq. up/down 12: Fixed-freq. setpoint 1 13: Fixed-freq. setpoint 2 14: Fixed-freq. setpoint 3 15: Select Acc./Dec. time 16: Pause PID 17: Pause traverse (keeps at output freq.) 18: Reset traverse (return to center freq.) 19: Forbid ACC./DEC	58

NVF2G series frequency converter

Para.No.	Name	Default	Range	Unit	Attr.	Description	No.
						20: Reversed 21: Clear freq. up/down temporarily 22: Sleep on/off 23~25: Reversed	
F5.06	On-off fliter times	5	1~10	/	○	1~10	59
F5.07	Terminal control running mode	0	1~3	/	◎	0: 2-wire control mode 1 1: 2-wire control mode 2 2: 3-wire control mode 1 3: 3-wire control mode 2	60
F5.08	UP/DOWN setting change rate	0.50	0.01~50.00	Hz/s	○	0.01Hz/s~50.00Hz/s	61
F5.09	AI1 lower limit	0.00	0.00~10.00	V	○	0.00V~10.00V	62
F5.10	AI1 lower limit corresponding setpoint	0.0	-100.0~100.0	%	○	-100.0%~100.0%	63
F5.11	AI1 upper limit	10.00	0.00~10.00	V	○	0.00V~10.00V	64
F5.12	AI1 upper limit corresponding setpoint	100.0	-100.0~100.0	%	○	-100.0%~100.0%	65
F5.13	AI1 input filter time constant	0.10	0.00~10.00	s	○	0.00s~10.00s	66
F5.14	AI2 lower limit	2.00	0.00~10.00	V	○	0.00V~10.00V	67
F5.15	AI2 lower limit corresponding setpoint	0.0	-100.0~100.0	%	○	-100.0%~100.0%	68
F5.16	AI2 upper limit	10.00	0.00~10.00	V	○	0.00V~10.00V	69
F5.17	AI2 upper limit corresponding setpoint	100.0	-100.0~100.0	%	○	-100.0%~100.0%	70
F5.18	AI2 input filter time constant	0.10	0.00~10.00	s	○	0.00s~10.00s	71
F6 output terminals group							

NVF2G series frequency converter

Para.No.	Name	Default	Range	Unit	Attr.	Description	No.
F6.00	Y1 output selection	1	0~10	/	○	0: No function	72
F6.01	R1 output selection	3	0~10	/	○	1: Run forward 2: Run reverse 3: Fault output 4: FDT reached	73
F6.02	R2 output selection	1	0~10	/	○	5: Frequency reached 6: Zero speed runing 7: Upper frequency limit reached 8: Lower frequency limit reached 9~10: Reversed	74
F6.03	AO1 output selection	0	0~10	/	○	0: Running freq. 1: Freq. setpoint 2: Running rotational speed 3: Output current 4: Output voltage 5: Output power 6: Output torque 7: AI1 input 8: AI2 input 9~10: Reversed	75
F6.04	AO1 output lower limit	0.0	0.0~100.0	%	○	0.0%~100.0%	76
F6.05	AO1 lower limit corresponding output	0.00	0.00~10.00	V	○	0.00V ~10.00V	77
F6.06	AO1 output upper limit	100.0	0.0~100.0	%	○	0.0%~100.0%	78
F6.07	AO1 upper limit corresponding output	10.00	0.00~10.00	V	○	0.00V ~10.00V	79
F6.08	AO2 output selection	0	0~10	/	○	0: Running freq. 1: Freq. setpoint 2: Running rotational speed 3: Output current 4: Output voltage 5: Output power 6: Output torque 7: AI1 input 8: AI2 input 9~10: Reversed	80
F6.09	AO2 output lower limit	0.0	0.0~100.0	%	○	0.0%~100.0%	81

NVF2G series frequency converter

Para.No.	Name	Default	Range	Unit	Attr.	Description	No.
F6.10	AO2 lower limit corresponding output	0.00	0.00~10.00	V	○	0.00V ~10.00V	82
F6.11	AO2 output upper limit	100.0	0.0~100.0	%	○	0.0%~100.0%	83
F6.12	AO2 output upper limit corresponding output	10.00	0.00~10.00	V	○	0.00V ~10.00V	84
F7 Display interface group							
F7.00	User password	0	0~65535	/	○	0~65535	85
F7.01	Reversed	/	/	/	/	/	86
F7.02	Reversed	/	/	/	/	/	87
F7.03	JOG key function	0	0~2	/	◎	0: JOG run 1: Forward/reversed switch 2: Clear UP/DOWN setting	88
F7.04	STOP key function	0	0~3	/	○	0: valid when panel control 1: valid when panel and terminal control 2: valid when panel and communication control 3: valid for all control	89
F7.05	Reversed	/	/	/	/	/	90
F7.06	Parameter displayed in runnig status	00FF	0~7FFF	/	○	0~0x7FFF BIT0: Running freq. BIT1: Setpoint freq. BIT2: DC bus voltage BIT3: Output voltage BIT4: Output current BIT5: Rotional speed BIT6: Output power BIT7: Output torque BIT8: PID given BIT9: PID feedback BIT10: Input terminal status BIT11: Output terminal status BIT12: AI1 BIT13: AI2 BIT14: FF number BIT15: Reversed	91
F7.07	Parameter displayed in stop status	00FF	1~1FF	/	○	1~0x1FF BIT0: Setpoint freq.	92

NVF2G series frequency converter

Para.No.	Name	Default	Range	Unit	Attr.	Description	No.
						BIT1: DC bus voltage BIT2: Input terminal status BIT3: Output terminal status BIT4: PID given BIT5: PID feedback BIT6: AI1 BIT7: AI2 BIT8: FF number BIT9~ BIT15: Reversed	
F7.08	Factory paramter	/	/	/	●	/	93
F7.09	IGBT module temperture	/	0~100.0	℃	●	0℃~100.0℃	94
F7.10	Factory paramter	/		/	●	/	95
F7.11	Accumulated running time	0	0~XXXXH	/	●	0~XXXXH	96
F7.12	Third latest fault type	/	0~26	/	●	0~24 0: No fault	97
F7.13	Second latest fault type	/	0~26	/	●	1: IGBT fault (OUT1) 2: Reversed	98
F7.14	Latest fault type	/	0~26	/	●	3: Reversed 4: Over-current when ACC. (OC1) 5: Over-voltage when DEC. (OC2) 6: Over-current at constant speed (OC3) 7: Over-voltage when ACC. (OV1) 8: Over-voltage when DEC. (OV2) 9: Over-voltage at constant speed (OV3) 10: DC bus under voltage (UV) 11: Motor overload (OL1) 12: Frequency converter overload (OL2) 13: Reversed 14: Reversed 15: Reversed	99

NVF2G series frequency converter

Para.No.	Name	Default	Range	Unit	Attr.	Description	No.
						16: Over-heat (OH2) 17: External fault (EF) 18: Communication fault (CE) 19: Current detection fault (ItE) 20: Motor identification fault (tE) 21: EEPROM fault (EEP) 22: PID feedback fault (PIDE) 23: Reversed 24: Output open-phase (SPO) 25: Input open-phase (PL) 26: Reversed	
F7.15	Running freq. at current fault	0.00	/	Hz	●	/	100
F7.16	Output current at current fault	0.0	/	A	●	/	101
F7.17	DC bus voltage at current fault	0.0	/	V	●	/	102
F7.18	Input terminal status at current fault	0	/	/	●	/	103
F7.19	Output terminal status at current fault	0	/	/	●	/	104
F8 enhanced function							
F8.00	ACC. Time 2	Set by motor	0.1~3600.0	s	○	0.1s~3600.0s	105
F8.01	DEC. time 2	Set by motor	0.1~3600.0	s	○	0.1s~3600.0s	106
F8.02	JOG freq.	5.00	0.00~F0.04	Hz	○	0.00Hz~F0.04 (max. freq.)	107
F8.03	JOG acc. time	Set by motor	0.1~3600.0	s	○	0.1s~3600.0s	108
F8.04	JOG dec. time	Set by motor	0.1~3600.0	s	○	0.1s~3600.0s	109
F8.05	Skip freq.	0.00	0.00~F0.04	Hz	○	0.00Hz~F0.04 (max. freq.)	110

NVF2G series frequency converter

Para.No.	Name	Default	Range	Unit	Attr.	Description	No.
F8.06	Skip freq. amplitude	0.00	0.00~F0.04	Hz	○	0.00~F0.04 (max. freq.)	111
F8.07	Traverse amplitude	0.0	0.0~100.0	%	○	0.0% ~ 100.0% (Relative to freq. setpoint)	112
F8.08	Jitter freq. amplitude	0.0	0.0%~50.0%	%	○	0.0% ~ 50.0% (Relative to traverse amplitude)	113
F8.09	Ramp-up time of traverse	5.0	0.1~3600.0	s	○	0.1s~3600.0s	114
F8.10	Ramp-down time of traverse	5.0	0.1~3600.0	s	○	0.1s~3600.0s	115
F8.11	Fault auto reset times	0	0~3	/	○	0~3	116
F8.12	Auto reset interval	1.0	0.1~100.0	s	○	0.1s~100.0s	117
F8.13	FDT level	50.00	0.00~F0.04	Hz	○	0.00Hz~ F0.04 (max. freq.)	118
F8.14	FDT lag	5.0	0.0~100.0	%	○	0.0%~100.0% (FDTlevel)	119
F8.15	Freq. arrive detecting range	0.0	0.0~100.0	%	○	0.0%~100.0% (max. freq.)	120
F8.16	Brake threshold voltage	130.0 120.0	115.0~140.0	%	○	115.0% ~ 140.0% (standard DC bus voltage) (380V series) 115.0% ~ 140.0% (standard DC bus voltage) (220V series)	121
F8.17	Rotational speed display coefficient	100.0	0.1~1000.0	%	○	0.1%~1000.0% Rotational speed=120*running frequency*F8.17/motor pole-pairs (n=120*f*F8.17/2p)	122
F9 PID control group							
F9.00	PID source selection	0	0~4	/	○	0: Panel (F9.01) 1: AI1 2: AI2 3: Communication 4: Fixed frequency	123
F9.01	Panel PID preset	0.0	0.0~100.0	%	○	0.0%~100.0%	124
F9.02	PID feedback source	0	0~3	/	○	0: AI1 feedback	125

NVF2G series frequency converter

Para.No.	Name	Default	Range	Unit	Attr.	Description	No.
	selection					1: AI2 feedback 2: AI1+AI2 feedback 3: Communication feedback	
F9.03	PID output characteristic	0	0~1	/	○	0: Positive 1: Negative	126
F9.04	Proportional gain (K)	1.00	0.00~100.00	/	○	0.00~100.00	127
F9.05	Integral time (Ti)	0.10	0.01~10.00	s	○	0.01s~10.00s	128
F9.06	Differential time (Td)	0.00	0.00~10.00	s	○	0.00s~10.00s	129
F9.07	Sampling cycle (T)	0.10	0.01~100.00	s	○	0.01s~100.00s	130
F9.08	PID deviation limit	0.0	0.0~100.0	%	○	0.0%~100.0%	131
F9.09	PID feedback lost detecting value	0.0	0.0~100.0	%	○	0.0%~100.0%	132
F9.10	PID feedback lost detecting time	1.0	0.0~3600.0	s	○	0.0s~3600.0s	133
F9.11	Pump sleep enable	0	0~3	/	○	0~3	134
F9.12	Delay time	60.0	0.0~3600.0	s	○	0.0s~3600.0s	135
F9.13	Awake pressure	80.0	0.0~100.0	%	○	0.0%~100.0%	136
F9.14	Speed/current limit	50.0	0.0~100.0	%	○	0.0%~100.0%	137
FA Fixed frequency control group							
FA.00	Muti-speed control method	0	0~3	/	○	0~3	138
FA.01	Muti-speed 0	0.0	-100.0~100.0	%	○	-100.0%~100.0%	139
FA.02	Muti-speed 1	0.0	-100.0~100.0	%	○	-100.0%~100.0%	140
FA.03	Muti-speed 2	0.0	-100.0~100.0	%	○	-100.0%~100.0%	141
FA.04	Muti-speed 3	0.0	-100.0~100.0	%	○	-100.0%~100.0%	142

NVF2G series frequency converter

Para.No.	Name	Default	Range	Unit	Attr.	Description	No.
FA.05	Muti-speed 4	0.0	-100.0~100.0	%	○	-100.0%~100.0%	143
FA.06	Muti-speed 5	0.0	-100.0~100.0	%	○	-100.0%~100.0%	144
FA.07	Muti-speed 6	0.0	-100.0~100.0	%	○	-100.0%~100.0%	145
FA.08	Muti-speed 7	0.0	-100.0~100.0	%	○	-100.0%~100.0%	146
FA.09	Muti-speed running time 0	1.0	0.0~3600.0	s	○	0.0s~3600.0s	147
FA.10	Muti-speed running time 1	1.0	0.0~3600.0	s	○	0.0s~3600.0s	148
FA.11	Muti-speed running time 2	1.0	0.0~3600.0	s	○	0.0s~3600.0s	149
FA.12	Muti-speed running time 3	1.0	0.0~3600.0	s	○	0.0s~3600.0s	150
FA.13	Muti-speed running time 4	1.0	0.0~3600.0	s	○	0.0s~3600.0s	151
FA.14	Muti-speed running time 5	1.0	0.0~3600.0	s	○	0.0s~3600.0s	152
FA.15	Muti-speed running time 6	1.0	0.0~3600.0	s	○	0.0s~3600.0s	153
FA.16	Muti-speed running time 7	1.0	0.0~3600.0	s	○	0.0s~3600.0s	154
Fb protection function group							
Fb.00	Motor over-load protection	2	0~2	/	◎	0: Disabled 1: Normal motor (with low speed compensation) 2: Variable frequency motor (without low speed compensation)	155
Fb.01	Motor overload protecting current	100.0	20.0~120.0	%	○	20.0%~120.0% (motor rated current)	156

NVF2G series frequency converter

Para.No.	Name	Default	Range	Unit	Attr.	Description	No.
Fb.02	Threshold of trip-free	80.0	70.0~110.0	%	○	70.0% ~ 110.0% (standard DC bus voltage)	157
Fb.03	Decrease rate of trip-free	0.00	0.00~F0.04	Hz	○	0.00Hz~F0.04 (max. freq.)	158
Fb.04	Overvoltage stall protection	1	0~1	/	○	0: Disabled 1: Enable	159
Fb.05	Overvoltage stall protecting voltage	140	110~150 (380V series)	%	○	110%~150% (380V series)	160
		115	110~150 (220V series)			110%~150% (220V series)	
Fb.06	Auto current limiting threshold	T type: 160 P type: 120	100~200	%	○	100%~200%	161
Fb.07	Reversed	/	/	/	/	/	162
FC serial communication group							
FC.00	Local address	1	0~247	/	○	1~247, 0: broadcast address	163
FC.01	Baud rate selection	3	0~5	bps	○	0: 1200bps 1: 2400bps 2: 4800bps 3: 9600bps 4: 19200bps 5: 38400bps	164
FC.02	Data format check setting	0	0~17	/	○	0: No check (N, 8, 1) for RTU 1: Even check (E, 8, 1) for RTU 2: Odd check (O, 8, 1) for RTU 3: No check (N, 8, 2) for RTU 4: Even check (E, 8, 2) for RTU 5: Odd check (O, 8, 2) for RTU 6: No check (N, 7, 1) for ASCII	165

NVF2G series frequency converter

Para.No.	Name	Default	Range	Unit	Attr.	Description	No.
						7: Even check (E, 7, 1) for ASCII	166
						8: Odd check (O, 7, 1) for ASCII	
						9: No check (N, 7, 2) for ASCII	
						10: Even check (E, 7, 2) for ASCII	
						11: Odd check (O, 7, 2) for ASCII	
						12: No check (N, 8, 1) for ASCII	
						13: Even check (E, 8, 1) for ASCII	
FC.03	Communication respond delay time	5	0~200	ms	○	0ms~200ms	166
FC.04	Communication timeout fault time	0.0	0.0~100.0	s	○	0.0 (invalid), 0.1s~100.0s	167
FC.05	Communication error action	1	0~3	/	○	0: Alarm and electrical stop 1: No alarm and continue to run 2: No alarm but stop according to F1.05 (only valid in communication control) 3: : No alarm but stop according to F1.05 (under all control)	168
FC.06	Response action	0	0~1	/	○	0: Response to writing 1: No response to writing	169
Fd supplementary function group							
Fd.00	Oscillation suppression	5	0~500	/	○	0~500	170

Para.No.	Name	Default	Range	Unit	Attr.	Description	No.
	low-frequency threshold						
Fd.01	Oscillation suppression high-frequency threshold	100	0~500	/	○	0~500	171
Fd.02	Oscillation suppression amplitude limit	5000	0~10000	/	○	0~10000	172
Fd.03	Oscillation suppression high and low frequency deviding boundaries	12.50	0.00Hz~F0.04	Hz	○	0.00Hz~F0.04 (max. freq.)	173
Fd.04	Oscillation suppression	1	0~1	/	○	0: Enabled 1: Disabled	174
Fd.05	PWM mode selection	0	0~1	/	◎	0: PWM mode 1 1: PWM mode 2	175
Fd.06	Reversed	/	/	/	/	/	176
Fd.07	Reversed	/	/	/	/	/	177
Fd.08	Reversed	/	/	/	/	/	178
Fd.09	Reversed	/	/	/	/	/	179
FE factory parameter group							
FE.00	Factory password	*****	0~65535		●	0~65535	180

Chapter 6 Detailed introductions to Parameter

F0 Basic Function group

Para. No	Name	Description	Range	Default
F0.00	Speed control mode	0: Vector control without PG 1: V/F control	0~1	Set by motor

Parameter to select the control method

Value:

0: Vector control without PG

Open-loop vector control: Suitable for universal high performance applications without encoder. One frequency converter only drives one motor, such as machine tools, centrifuge, drawbench, injection molding machine. If speed variation is caused by load, please set parameter F3.06. This mode requires higher accuracy of motor parameter.

1: V/F control

Suitable for applications which require less control accuracy or with more loads, as fans and pumps. If speed variation is caused by load, please set parameter F4.03.

This mode requires less accuracy of motor parameter.

Para. No	Name	Description	Range	Default
F0.01	Run command channel	0: Panel control 1: Terminal control 2: Communication control	0~2	0

Parameter to select command source

Running command include: Run, Stop, Forward, Reverse, JOG, Fault, Reset, etc.

Value:

0: Panel control ('LOC/REM' lamp off). The operation can be controlled by Run/Stop keys on panel. If F7.03=1, press JOG key to change rotational orientation;

1: Terminal control ('LOC/REM' lamp flashing). The operation can be controlled by terminals;

2: Communication control ('LOC/REM' lamp on). The operation can be controlled by host communication.

Para. No	Name	Description	Range	Default
F0.02	Keyboard and terminal UP/DOWN	0: Valid, save parameter when powered off 1: Valid, not save parameter when	0~3	0

Para. No	Name	Description	Range	Default
	setting	powered off 2: Reserved 3: Reserved		

Frequency can be set by ▲/▼ keys on panel or terminal UP/DOWN. This combines any other frequency setting method to realize fine tuning of frequency while commissioning.

0: Valid, save parameter when powered off. Frequency can be set by this parameter. If frequency converter powered-off, the settings are stored. If frequency converter powered-on again, system will automatically combine with current frequency;

1: Valid, not save parameter when powered off. Frequency can be set, but the settings are not saved when powered off;

2: Reserved;

3: Reserved.

Para. No	Name	Description	Range	Default
F0.03	Selection of freq. command	0: Panel setpoint (F0.07) 1: AI1 setpoint 2: AI2 setpoint 3: AI1+ AI2 setpoint 4: FF setpoint 5: PID setpoint 6: Communication setpoint	0~6	0

Parameter to select frequency, there are 7 main setpoints:

0: Panel setpoint, main setpoint is determined by panel set (F0.07);

1: AI1 setpoint, main setpoint is determined by AI1 channel (J601 position on CPU board:

1 and 2: 0V~10V analog voltage input. 2 and 3: panel potentiometer input.);

2: AI2 setpoint, main setpoint is determined by AI2 channel (J602 position on CPU board:

1 and 2: 0V~10V analog voltage input. 2 and 3: 0mA~20mA analog current input.);

3: AI1+ AI2 setpoint, main setpoint is determined by AI1+ AI2;

Value 0,1,2,3 indicates that the frequency is set by analog input terminals. NVF2G series frequency converter has 2 analog input terminals: NVF2G series frequency converter has two analog input terminals. AI1 is 0V~10V voltage-type input. Frequency can be changed by the panel potentiometer or terminal AI1 which is chosen by switching J601.

AI2 is 0V~10V voltage-type input or 0(4) mA ~20mA current-type input. Current and voltage are chosen by switching J602.

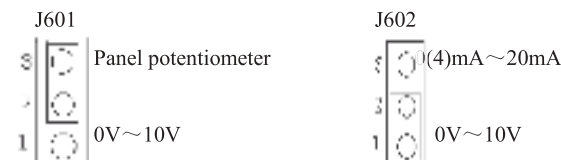

Note: The setpoint value is relative, setpoint value=100 % corresponds to maximum frequency (F0.05).

4: FF setpoint, frequency converter runs at fixed frequency. Parameter group F5 and FA need to be set to define the relationship between percentage and frequency;

5. PID setpoint, frequency converter runs under PID control. Parameter group F9 has to be set. Please refer to Parameter group F9;

6: Remote communication setpoint, frequency is given from the host by communication. Please refer to Parameter group F11.

Para. No	Name	Description	Range	Default
F0.04	Max. output frequency	10.00Hz~400.00Hz	10.00~400.00	50.00Hz

Sets maximum output frequency of frequency converter

It is the basic of frequency settings, and also the basis of speed acceleration and deceleration, please pay attention to.

Para. No	Name	Description	Range	Default
F0.05	Upper running freq. limit	F0.06~F0.04 (max. freq.)	F0.06~F0.04	50.00Hz

The upper limit of frequency converter output frequency, this value ≤ maximum output frequency

Para. No	Name	Description	Range	Default
F0.06	Lower running freq. limit	0.00Hz~F0.05 (Running freq. upper limit)	0.00~F0.05	0.00Hz

The lower limit of frequency converter output frequency. If frequency setpoint < lower limit, frequency converter runs at lower limit.

Where, $f(\text{max. output}) \geq f(\text{upper limit}) \geq f(\text{lower limit})$

Para. No	Name	Description	Range	Default
F0.07	Panel freq. setpoint	0.00Hz~F0.04 (max. freq.)	0.00~F0.04	50.00Hz

If F0.03=0, the value of F0.07 is initial value for digital setpoint

Para. No	Name	Description	Range	Default
F0.08	Acc. time 0	0.1s~3600.0s	0.1~3600.0	Set by motor
F0.09	Dec. time 0	0.1s~3600.0s	0.1~3600.0	Set by motor

Time taken for frequency converter to accelerate from 0Hz up to maximum frequency

Time taken for frequency converter to decelerate from maximum frequency down to 0Hz

Please refer to the following figure

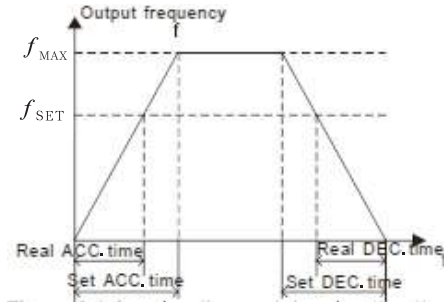

Fig. 6.1 Acc. time and dec. time

If setpoint frequency = maximum frequency, the actual Acc. and Dec. time= Acc. and Dec. time setpoint. If setpoint frequency<maximum frequency, the actual Acc. time < Acc. and Dec. time setpoint.

The actual Acc. and Dec. time = Acc. and Dec. time setpoint × (Frequency setpoint / max. Frequency)

NVF2G series frequency converter has 2 group acceleration and deceleration times.

Group 1: F0.08、F0.09;

Group 2: F8.00、F8.01.

Acc. and dec. time can be selected by multi-function digital input terminal (F5 group).

Factory acc. and dec. time for 5.5kW and below models is 10.0s, and for 7.5kW to 55kW mode is 20.0s, and for 75kW and above models is 40.0s

Para. No	Name	Description	Range	Default
F0.10	Selection of running direction	0: Default direction; 1: Reverse; 2: Disable reverse	0~2	0

0: Default direction, after powered on, the motor runs in actual direction;

1: Reverse, changes motor direction to opposite by this parameter without any other changes, the affect is same as changing either two of ouput power line (U.V.W);

Note: After parameter initialization, the direction of motor will be back to the

original status. Please use this parameter with caution for some applications in which motor direction is not allowed to change.

2: Disable reverse, for some applications in which motor direction is not allowed to change.

Para. No	Name	Description	Range	Default
F0.11	Carrier freq. setpoint	0.5kHz~15.0kHz	0.5~15.0	Set by motor

This function is mainly used to improve the noise and interference of the frequency converter.

Advantages of high carrier frequency: much ideal current waveforms, less harmonic current, less noise; and disadvantages: increasing switch losses, higher temperature of the frequency converter and lower the output power. In the high carrier frequency status, the frequency converter must be used derating. At the same time, leakage current of Frequency converter will increase, and the electromagnetic interference will increase. Advantages and disadvantages of Low carrier frequency is opposite, too low carrier frequency will cause instability in low-frequency operation, lower torque and even oscillation.

The frequency converters have a reasonable setting when they leave factory. In normal occasions, users do not need to change this parameter.

This parameter shall be changed reasonable in the following conditions:

1. To reduce the noise;
2. To reduce the interference;
3. If the cables between frequency converter and motor are too long.

Frequency	Electromagnetic noise	Noise, leakage current	Radiating
1.0kHz	large ↑ ↓ small	small ↑ ↓ large	small ↑ ↓ large
10kHz			
15kHz			

Fig. 6.2 Effect of carrier frequency

Relationship between models of frequency converter and carrier frequency

Model	Carrier frequency	Max. carrier frequency (kHz)	Min. carrier frequency (kHz)	Default (kHz)
T type: 1.5kW~7.5kW P type: 1.5kW~11kW		15	1	8
T type: 15kW~55kW P type: 18.5kW~75kW		8	1	4

T type: 75kW and above P type: 90kW and above	6	1	2
--	---	---	---

Relationship between length of cable and carrier frequency

Cable length between motors	Carrier frequency
<50m	10kHz
<100m	<5kHz
<100m	<2.5kHz

Para. No	Name	Description	Range	Default
F0.12	Motor parameter automatically identification	0: No operation 1: Comprehensive identification 2: Static identification	0~2	0

0: No operation, disable identification;

1: Comprehensive identification

Before identification, please make sure the following item:

1. Make sure motor without load and stable. If there is load, the parameter after identification may be wrong and the frequency converter may be abnormal.
2. Please enter correct parameters (F2.01 ~ F2.05) in motor nameplate, otherwise the detected value may be wrong;
3. Acc. and dec. time (F0.08、 F0.09) shall be set according to the inertia of motor. Otherwise there may be overcurrent fault while identification.

Parameter identification process:

Set F0.12=1, press SET key, now enters into identification, and display “-TUN-“ in LED panel and flash. Then press RUN key, identification begins, and display “TUN-0” after motor run, display “TUN-1” and “RUN/PRG” lamp flash. After identification is finished, display “-END-” and return to stop interface.

While “-TUN-” flashing, press PRG key to exit parameter identification, and then press STOP key to stop identification in the whole process.

Note: start and stop of parameter identification only can be controlled by panel, after finished, its value returns to zero.

2: Parameter static automatically identification

Motor is suggested with no load. Before identification, motor parameters (F2.00 ~ F2.04) in nameplate must be entered correctly.

Parameter identification can detect stator resistance, rotor resistance and leakage inductance, but mutual inductance and no-load current can not be detected, please

enter these two parameters according to your experience

Para. No	Name	Description	Range	Default
F0.13	Parameter initialization	0: Disabled 1: Reset to default values 2: Clear fault record	0~2	0

1: Reset all parameters to default values;

2. Clear all fault records

The value of parameter will reset to zero when complete the operation

Para. No	Name	Description	Range	Default
F0.14	Auto voltage regulation	0: Invalid 1: Valid all time 2: Invalid at slow down	0~2	2

If grid voltage changes this function maintains a constant output voltage automatically. If this function is invalid, output voltage will change with input voltage (or DC bus voltage), otherwise the output voltage will not change with input voltage (or DC bus voltage). The output voltage keeps constantly in output capability.

Note: if P410=0 is in slow down, the motor will stop in a shorter period of time without overvoltage.

F1 Start/stop control group

Para. No	Name	Description	Range	Default
F1.00	Motor start method	0: Direct start 1: DC braking start 2: Flying start	0~2	0

0: Direct start: Starts at (F1.01) within set maintain time (F1.02), suitable for most motor with low inertia.

1: DC braking start: DC braking first (Note: F1.03 and F1.04 shall be set), then start the motor at start frequency. This function applies to the applications in which small load may reverse.

2: Flying start: if accepts running command, the frequency converter is started by rapidly changing the output frequency until the actual motor speed has been found, then the motor runs up to setpoint. It starts rotating motor smoothly without impact, suitable for large inertia load which may instantaneously shut down and restart.

Para. No	Name	Description	Range	Default
F1.01	Start frequency of direct start	0.00Hz~10.00Hz	0.00~10.00	0.00Hz

F1.02	Hold time of start frequency	0.00s~50.0s	0.00~50.0	0.0s
--------------	------------------------------	-------------	-----------	------

Appropriate start frequency can increase the start torque. During frequency maintain time (F1.02), the output frequency is start frequency (F1.01), and then runs from F1.01 up to setpoint. If frequency setpoint < start frequency (F1.01), frequency converter will not run. Start frequency is not restricted by lower-limit frequency. If forward/reverse switches, start frequency is invalid.

Para. No	Name	Description	Range	Default
F1.03	DC braking current before start	0.0%~150.0%	0.0~150.0	0.0%
F1.04	DC braking duration before start	0.0s~50.0s	0.0~50.0	0.0s

Defines level of DC current in [%] relative to rated motor current. First braking at braking current (F1.03) and then after braking duration (F1.04) frequency converter starts to accelerate. If F1.04=0, DC braking is invalid. The greater the DC braking current the bigger the braking force.

Para. No	Name	Description	Range	Default
F1.05	Motor stop method	0: Ramp-down stop 1: Electrical stop	0~1	0

0: Ramp-down stop

When stop command is received, the output frequency starts to ramp to 0 Hz within the set stop time;

1: Electrical stop, when stop command is received, the output frequency falls to 0Hz.

Para. No	Name	Description	Range	Default
F1.06	DC braking start frequency at stop	0.00Hz~10.00Hz	0.00~10.00	0.00Hz
F1.07	DC braking waiting time at stop	0.0s~50.0s	0.0~50.0	0.0s
F1.08	DC braking current at stop	0.0%~150.0%	0.0~150.0	0.0%
F1.09	DC braking duration at stop	0.0s~50.0s	0.0~50.0	0.0s

Starting frequency of DC braking: start the DC braking when running frequency reaches this frequency. Waiting time: before inject DC braking, frequency converter output pulses are blocked, wait for this time, DC braking starts. DC current is not applied until the motor has been sufficiently demagnetized. This function is used to prevent over-current fault caused by high speed. DC braking current: the value is in % relative to rated current. The bigger the DC braking current is, the greater the

braking torque is. DC braking time: time taken for DC braking. If t=0, DC braking is invalid.

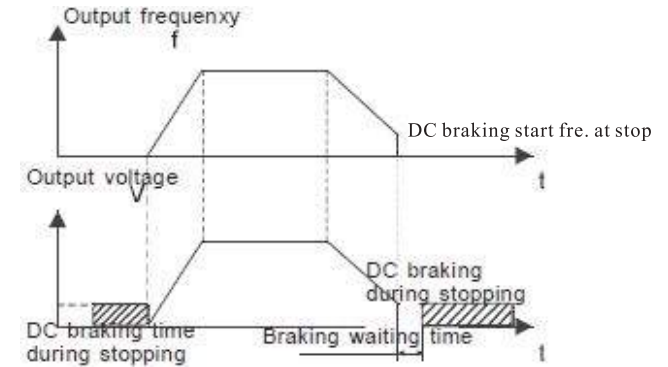

Fig. 6.3 DC braking diagram

Para. No	Name	Description	Range	Default
F1.10	Deadband time of Forward / reverse	0.0s~3600.0s	0.0~3600.0	0.0s

Set the hold time at zero frequency in transition between forward and reverse running. Shown as fig. 6.4

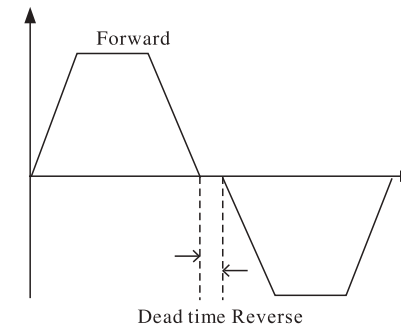

Fig. 6.4 Deadband time of Forward / Reverse

Para. No	Name	Description	Range	Default
F1.11	Protect action when power is on	0: Command invalid when power is on 1: Command valid when power is on	0~1	0

If F0.01=1, system will detect terminal status when powered on.

0: Command invalid when power is on. During power on process, frequency converter will not start even if running terminal is active, until running terminal disabled and enabled again.

1: Command invalid when power is on. During power on process, if running terminal is active, after initialization, frequency converter will start automatically.

Note: this function may cause the frequency converter restart automatically and lead to serious consequences, please use it with caution.

F2 Motor Parameter group

Para. No	Name	Description	Range	Default
F2.00	Frequency converter type	0: T type 1: P type	0~1	Set by motor

0: suitable for constant torque load;

1: suitable for constant power load with variable torque (fans and pumps)

Para. No	Name	Description	Range	Default
F2.06	Stator resistance	0.001Ω~65.535Ω	0.001~65.535	Set by motor
F2.07	Rotor resistance	0.001Ω~65.535Ω	0.001~65.535	Set by motor
F2.08	Stator/ Rotor inductance	0.1mH~6553.5mH	0.1~6553.5	Set by motor
F2.09	Mutual inductance of stator and rotor	0.1mH~6553.5mH	0.1~6553.5	Set by motor
F2.10	Current without load	0.01A~655.35A	0.01~655.35	Set by motor

NVF2G series frequency converter provides parameter automatically identification and the accuracy of detection depends on correctly setting these parameters in motor nameplate. In order to assure the accuracy of control performance, please configure the motor according to the standard frequency converter. If the power of motor and frequency converter is far away from each other, the control performance will dramatic decline.

After identification, the values of F2.06~F2.10 will be automatically updated. These parameters are the basic parameters for high performance V/F control which have direct impact on the control performance.

Note: Do not change these parameters at will; otherwise it may deteriorate the control performance.

F3 vector control group

Para. No	Name	Description	Range	Default
----------	------	-------------	-------	---------

F3.00	Proportional gain 1 of speed controller	0~100	0~100	20
F3.01	Integration time 1 of speed controller	0.01s~10.00s	0.01~10.00	0.50s
F3.02	Low switching frequency	0.00Hz~F3.05	0.00~F3.05	5.00Hz
F3.03	Proportional gain 2 of speed controller	0~100	0~100	15
F3.04	Integration time 2 of speed controller	0.01s~10.00s	0.01~10.00	1.00s
F3.05	High switching frequency	F3.02~F0.04 (max. frequency)	F3.02~F0.04	10.00Hz

The above parameters are only valid for vector control but invalid for V/F control. If $f < F3.02$, K_p and K_i are F3.00 and F3.01. If $f > F3.05$, K_p and K_i are F3.03 and F3.04. If $F3.02 < f < F3.05$, K_p and K_i are the proportional to the bias between the two group parameters, as shown in fig. 6.5.

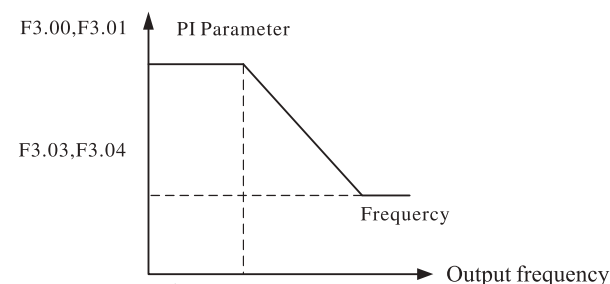

Fig. 6.5 PI parameters

The system dynamic response can be adjusted by setting the proportional gain and integration time of speed controller. The response can be faster if integration time (K_i) is decreased or proportional gain is increased. However if K_p is too large or K_i is too small, the system becomes overshoot and tends to oscillate. But if K_p is too small, the system may have steady oscillation or static floating. Please adjust these parameters according to actual situation.

Para. No	Name	Description	Range	Default
F3.06	Slip compensation factor for vector control	50%~200%	50~200	100%

The parameter is used to adjust the rotational frequency deviation for vector control and improve the precision of speed control. Properly adjusting this parameter can effectively restrain the static speed bias.

Para. No	Name	Description	Range	Default
F3.07	Torque upper limit setpoint	0.0% ~ 200.0% (frequency converter rated current)	0.0~200.0	T type: 150.0% P type: 120.0%

Setpoint in [%] relative to rated output current of frequency converter

F4 V/F control group

This function is valid for V/F control but invalid for vector control (F0.00=1).

Para. No	Name	Description	Range	Default
F4.00	V/f cure type	0: Linear V/f 1: Quadratic V/f (parabolic V/f)	0~1	0

0: Linear V/f curve, suitable for normal constant torque load

1: Quadratic V/f curve, suitable for variable torque load such as fans and pumps.

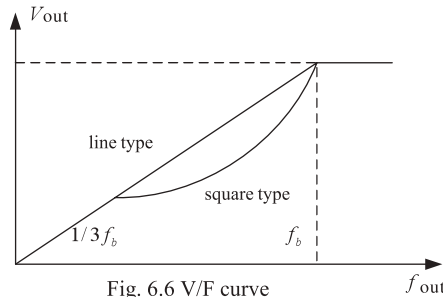

Fig. 6.6 V/F curve

Para. No	Name	Description	Range	Default
F4.01	Torque boost	0.0%: (auto) 0.1%~30.0%	0.0~30.0	0.0%
F4.02	Boost end frequency	0.0% ~ 50.0% (relative to rated motor frequency)	0.0~50.0	20.0%

Torque boost will take effect when output frequency is less than F4.02. Torque boost can improve the torque performance of V/F control at low speed. The value should be determined by the load. The heavier the load, the larger the value should be. If the boost is too large, the motor will run in exciting. The efficiency of motor will decrease when the current increases and the motor will overheat. When the torque boost is set to 1.0%, frequency converter is in automatic torque boost state.

Boost end frequency: the torque is valid under this point and invalid when exceeding this value.

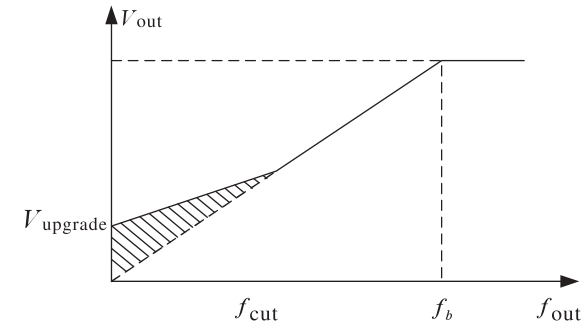

Fig. 6.7 Torque boost by hand

Para. No	Name	Description	Range	Default
F4.03	Slip compensation	0.0%~200.0%	0.0~200.0	0.0%

This function is used to improve speed accuracy when operating with a load. It is in [%] relative to rated slip frequency.

Para. No	Name	Description	Range	Default
F4.04	Energy saving control	0: Disabled 1: Enabled	0~1	0

While there is a light or empty load such as pumps and fans, it will reduce the frequency converter output voltage and save energy through detecting the load current.

Tip: This function is much more effective for fans and pumps.

F5 Input terminals group

NVF2G series frequency converter has 4 multi-functional digital input terminals and 2 analog input terminals.

Para. No	Name	Description	Range	Default
F5.00	Function of X1	Programmable multi-function terminal	0~25	1
F5.01	Function of X2	Programmable multi-function terminal	0~25	2
F5.02	Function of X3	Programmable multi-function terminal	0~25	4
F5.03	Function of X4	Programmable multi-function terminal	0~25	5
F5.04	Function of X5	Programmable multi-function terminal	0~25	7
F5.05	Function of X6	Programmable multi-function terminal	0~25	8

The functions of terminals are shown in following table:

Setpoint	Function	Description									
0	No function	Frequency converter not run even running command is input. Set unused terminals to be invalid to avoid malfunction									
1	Forward run	Control frequency converter forward/reverse running by external terminal.									
2	Reverse run										
3	Three-wire operation ctrl.	Determine the frequency converter in three-wire control mode. please refer to description of F5.05									
4	Forward JOG	Frequency, acc. and dec. time for jog run, please refer to description of F8.02, F8.03, F8.04									
5	Reverse JOG										
6	Electrical stop	Frequency converter blocks the output immediately. Motor stop process not controlled by frequency converter. This function is used often for large inertia load without stop time requirement. It is the same as electrical stop.									
7	Fault reset	Reset faults. It has the same function as STOP key. It can achieve rotate fault resetting									
8	External fault input	When it active, frequency converter alarms and stops									
9	Up command	Frequency can be changed by Up/down command when frequency is given by external terminals or frequency source is digital setpoint.									
10	Down command										
11	Clear freq. up/down	 <p>Clear up/down setting by this function in order to make frequency restored to setpoint frequency of command channel</p>									
12	FF setpoint 1	8 fixed frequencies can be realized by the combination of three terminals. Note: FF setpoint 1 is low bit and FF setpoint 3 is high bit									
13	FF setpoint 2										
14	FF setpoint 3										
15	Select Acc./Dec. time	<table border="1"> <thead> <tr> <th>Terminals</th> <th>Acc. and dec. time</th> <th>Parameters</th> </tr> </thead> <tbody> <tr> <td>OFF</td> <td>Acc. time 1</td> <td>F0.08、F0.09</td> </tr> <tr> <td>ON</td> <td>Acc. time 2</td> <td>F8.00、F8.01</td> </tr> </tbody> </table>	Terminals	Acc. and dec. time	Parameters	OFF	Acc. time 1	F0.08、F0.09	ON	Acc. time 2	F8.00、F8.01
Terminals	Acc. and dec. time	Parameters									
OFF	Acc. time 1	F0.08、F0.09									
ON	Acc. time 2	F8.00、F8.01									
16	Pause PID	PID function is paused, and frequency converter keep output frequency unchanged									
17	Pause traverse	Inverter keeps output frequency unchanged. If terminal disabled, frequency converter will continue to traverse with current frequency									
18	Reset traverse	Frequency is forced to center frequency									
19	Forbid ACC./DEC	Frequency converter is not effect by external signal (except for stop command) and maintains current output frequency.									
20	Reversed	Reversed									
21	Clear freq. up/down temporarily	UP/DOWN setting is invalid but will not be cleared. When this terminal is disabled, UP/DOWN value will be valid again									
22	Sleep on/off	After terminal enabled, pumps enter into sleep state									

Setpoint	Function	Description
23~25	Reversed	Reversed

Para. No	Name	Description	Range	Default
F5.06	On-off filter times	1~10	1~10	5

Sets filter time for X1 to X6 terminals. When interference is heavy, user should increase this value to prevent malfunction.

Para. No	Name	Description	Range	Default
F5.07	Terminal control running mode	0: 2-wire control mode 1 1: 2-wire control mode 2 2: 3-wire control mode 1 3: 3-wire control mode 2	0~3	0

This parameter defines four different control modes that control the frequency converter operation through external terminals.

0: 2-wire control mode 1. It is the most common control mode. X1 and X2 terminal command determines the direction.

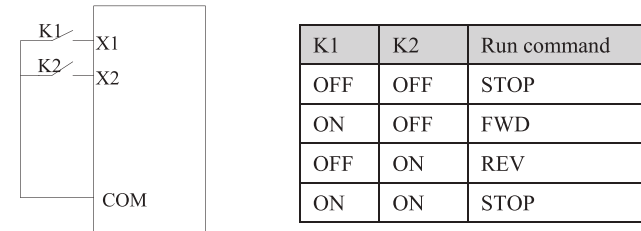

Fig. 6.8 2-Wire control mode 1

1: 2-wire control mode 2. X1 terminal enable in this mode. Direction is determined by terminal X2.

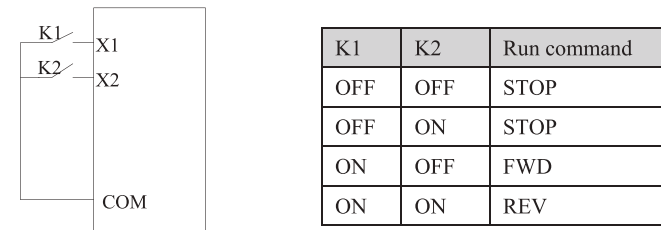

Fig. 2-wire control mode 2

2: 3-wire control mode 1

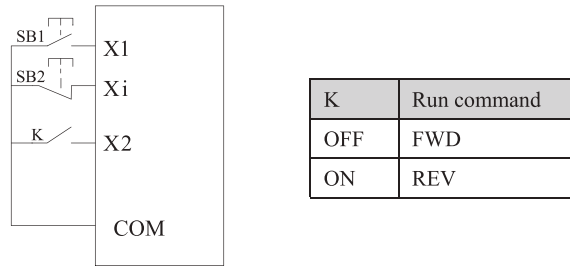

Fig. 6.10 3-wire control mode 1

Where, K: run direction button; SB1: start button; SB2: stop button
Terminal Xi is multifunction input terminal of X1 to X6. Terminal function should be set to 3 (3-wire control)

3: 3-wire control mode 2. Xi terminal is enabled. Start command comes from SB1 or SB3, and control running direction. Stop command comes from NC input of SB2

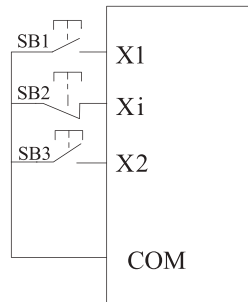

Fig. 6.11 3-wire control mode 2

Where, SB1: FWD button; SB2: stop button; SB3: REV button
Xi terminal function should be set to 3 (3-wire control)

Hint: when 2-wire control mode is active the frequency converter will not run if frequency converter is stop by other command source, even if X1/X2 terminal is enabled. if you want to run the frequency converter, you should enable X1/X2 terminal again.

Para. No	Name	Description	Range	Default
F5.08	UP/DOWN setting change rate	0.01Hz/s~50.00Hz/s	0.01 ~ 50.00	0.50Hz/s

Adjust changing rate of frequency by UP/DOWN terminals.

Para. No	Name	Description	Range	Default
F5.09	A11 lower limit	0.00V~10.00V	0.00~10.00	0.00V
F5.10	A11 lower limit corresponding setpoint	-100.0%~100.0%	-100.0~100.0	0.0%
F5.11	A11 upper limit	0.00V~10.00V	0.00~10.00	10.00V
F5.12	A11 upper limit corresponding setpoint	-100.0%~100.0%	-100.0~100.0	100.0%
F5.13	A11 filter time constant	0.00s~10.00s	0.00~10.00	0.10s

These parameters determine the relationship between analog input voltage and the corresponding setpoint value. When the analog input voltage exceeds the range between lower limit and upper limit, it will be regarded as the lower limit or the upper limit. If analog input is current, 0/4mA ~ 20mA current signal corresponds to 0V ~ 10V voltage signal. For different applications, the corresponding nominal value of 100.0% of analog setting is different. For details, please refer to description of each application.

Note: Lower limit of A11 must be less than or equal to upper limit of A11.

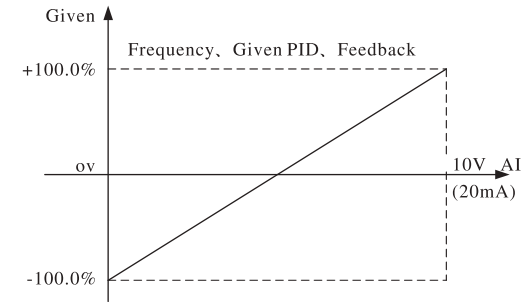

Fig. 6.12 Relationship between AI and corresponding setting

A11 filter time constant is effective when there are sudden changes or noise in the analog input signal, responsiveness decrease as the setting increase.

Para. No	Name	Description	Range	Default
F5.14	A12 lower limit	0.00V~10.00V	0.00~10.00	2V
F5.15	A12 lower limit corresponding setpoint	-100.0%~100.0%	-100.0~100.0	0.0%
F5.16	A12 upper limit	0.00V~10.00V	0.00~10.00	10.00V
F5.17	A12 upper limit	-100.0%~100.0%	-100.0~100.0	100.0%

	corresponding setpoint			
F5.18	AI2 filter time constant	0.00s~10.00s	0.00~10.00	0.10s

Please refer to description of AI1. AI2 provides 0V~10V or 0/4mA~20mA input. When AI2 is set as 0/4mA~20mA, the corresponding voltage range is 0V~10V.

F6 output terminals group

There are one multi-function digital output terminal, two multi-function relay output terminals and two multi-function analog output terminals.

Para. No	Name	Description	Range	Default
F6.00	Y1 output selection	Open collector output fun.	0~10	1
F6.01	R1 output selection	Relay output function	0~10	3
F6.02	R2 output selection	Relay output function	0~10	1

Relay and collector functions are shown as following table

Value	Function	Description
0	No function	Output terminal has no function
1	Run forward	Indicates frequency converter in forward running, has output frequency. Output signal is ON
2	Run reverse	Indicates frequency converter in reverse running, has output frequency. Output signal is ON
3	Fault output	In fault status, output signal is ON
4	FDT reached	Refer to description of F8.13, F8.14
5	Frequency reached	Refer to description of F8.15
6	Zero speed running	When output frequency < start frequency, output ON
7	Upper frequency limit reached	When running frequency reaches upper limit, output ON
8	Lower frequency limit reached	When running frequency reaches lower limit, output ON
9~10	Reversed	Reversed

Para. No	Name	Description	Range	Default
F6.03	AO1 output selection	Multi-function analog output	0~10	0
F6.04	AO1 lower limit	0.0%~100.0%	0.0~100.0	0.0%
F6.05	AO1 lower limit corresponding output	0.00V~10.00V	0.00~10.00	0.00V
F6.06	AO1 upper limit	0.0%~100.0%	0.0~100.0	100.0%
F6.07	AO1 upper limit corresponding output	0.00V~10.00V	0.00~10.00	10.00V
F6.08	AO2 output selection	Multi-function analog output	0~10	0
F6.09	AO2 lower limit	0.0%~100.0%	0.0~100.0	0.0%

F6.10	AO2 lower limit corresponding output	0.00V~10.00V	0.00~10.00	0.00V
F6.11	AO2 upper limit	0.0%~100.0%	0.0~100.0	100.0%
F6.12	AO2 upper limit corresponding output	0.00V~10.00V	0.00~10.00	10.00V

Standard output of AO1 and AO2 are 0/4mA~20mA or (0V~10V), can be selected by J603、J604, as shown as following:



Fig. 6.13 Output range

Value	Function	Range
0	Running frequency	0~maximum frequency
1	Frequency setpoint	0~maximum frequency
2	Motor running rotate speed	0~2*rated rotate speed
3	Output current	0~2*rated current
4	Output voltage	0~1.5*rated voltage
5	Output power	0~2*rated power
6	Output torque	0~2*motor rated current
7	AI1 input	0V~10V
8	AI2 input	0V~10V or 0/4mA~20mA
9~10	Reversed	Reversed

These parameters determine the relationship between analog output voltage and the corresponding setpoint value. When the analog output voltage exceeds the range between lower limit and upper limit, it will be regarded as the lower limit or the upper limit. If analog output is current, 1mA current signal corresponds to 0.5V voltage signal. For different applications, the corresponding nominal value of 100.0% of analog setting is different. For details, please refer to description of each application.

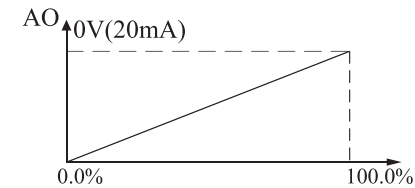

Fig. 6.14 Relationship between AI and corresponding setting

F7 Display interface group

Para. No	Name	Description	Range	Default
F7.00	User password	0~65535	0~65535	0

The password protection will be valid when F7.00 is set to be any nonzero data.

00000: user's password set before will be cleared and the password protection will be disabled. Restoring factory parameters also can clear user's password.

After the password has been set and becomes valid, the user can not access menu if the user's password is not correct. Only when a correct password is entered, the user can see and change parameters. Please keep user's password in mind.

Note: if you forget user's password, please ask for support.

The password becomes valid in 1min after quitting parameter editing state. Press PRG again to enter editing state, "0.0.0.0" will be displayed. Unless using the correct password, the operators can not enter it.

Para. No	Name	Description	Range	Default
F7.01	Reversed			0
F7.02	Reversed			

Para. No	Name	Description	Range	Default
F7.03	JOG key function	0: JOG run 1: Forward/reversed switch 2: Clear UP/DOWN setting	0~2	0

JOG key is a multi-function key, whose function can be defined by the value:

0: JOG run, press JOG key, frequency converter will jog

1: Forward/reversed switch, press it, the direction will reverse, only valid if F0.01=0

2: Clear UP/DOWN setting, press it the UP/DOWN will be cleared

Para. No	Name	Description	Range	Default
F7.04	STOP STOP key function	0: valid when panel control 1: valid when panel and terminal control 2: valid when panel and communication control 3: valid for all control	0~3	0

The reset function of stop key is always valid

Para. No	Name	Description	Range	Default
F7.05	Reversed			

Para. No	Name	Description	Range	Default
F7.06	Parameter displayed in running status	0~0x7FFF	0~0x7FFF	0xFF

If frequency converter is in running status, displayed parameter is determined by this

parameter. It is a 16-bit binary number, if a bit is set to 1, the corresponding parameters can be viewed through "SHIFT" key in the running status. If the bit is 0, the parameter will not be displayed. If you set parameter F7.06, the number must be transformed to hexadecimal format.

Low 8-bit data:

Bit7	Bit6	Bit5	Bit4	Bit3	Bit2	Bit1	Bit0
Output torque	Output power	Rotational speed	Output current	Output voltage	DC bus voltage	Setpoint freq.	Running freq.

High 8-bit data:

Bit7	Bit6	Bit5	Bit4	Bit3	Bit2	Bit1	Bit0
Reversed	FF number	A11	A12	Output terminal status	Input terminal status	PID feedback	PID given

State of input and output terminals is displayed with a decimal number. X1 (Y) corresponds to lastest bit, for example: if the output status is 3, refers that terminal X1、X2 are closed, and other terminals are open. Please refers to the description of F7.18、F7.19.

Para. No	Name	Description	Range	Default
F7.07	Parameter displayed in stop status	0~0x1FFF	0~0xFF	0xFF

Set method is the same to F7.06. But in stop status, the display of parameter is affected by this code.

Low 8-bit data:

Bit7	Bit6	Bit5	Bit4	Bit3	Bit2	Bit1	Bit0
A12	A11	PID feedback	PID given	Output terminal status	Input terminal status	DC bus voltage	Setpoint freq.

High 8-bit data:

Bit7	Bit6	Bit5	Bit4	Bit3	Bit2	Bit1	Bit0
Reversed	Reversed	Reversed	Reversed	Reversed	Reversed	Reversed	FF number

Para. No	Name	Description	Range	Default
F7.08	Factory paramter	0°C~100.0°C		
F7.09	IGBT module temperture	0°C~100.0°C		
F7.10	Factory paramter			
F7.11	Accumulated running time	0h~65535h		

These parameters can only be viewed, can not be changed.

IGBT module temperture shows IGBT module temperature, the value of IGBT

module over-temperature protection may be different.

Accumulated running time: the frequency converter total running time.

Para. No	Name	Description	Range	Default
F7.12	Third latest fault type	0~26	0~26	/
F7.13	Second latest fault type	0~26	0~26	/
F7.14	Latest fault type	0~26	0~26	/

These parameters record the last three fault types: 0 for no fault, 1 ~ 24 for 24 kinds of different faults. See detailed fault analysis.

Para. No	Name	Description	Range	Default								
F7.15	Output freq. at current fault	Output frequency of current failure	/	/								
F7.16	Output current at current fault	Output current of current failure	/	/								
F7.17	DC bus voltage at current fault	Bus voltage of current failure	/	/								
F7.18	Input terminal status at current fault	This value is decimal. Show the status of digital input terminal of most recent fault. The order is shown as follow <table border="1" style="margin-left: 20px;"> <tr> <td>BIT3</td> <td>BIT2</td> <td>BIT1</td> <td>BIT0</td> </tr> <tr> <td>X4</td> <td>X3</td> <td>X2</td> <td>X1</td> </tr> </table> If the input terminal is ON the corresponding value is 1 while OFF is corresponding to 0. This value can reflect the status of digital input signals	BIT3	BIT2	BIT1	BIT0	X4	X3	X2	X1	/	/
BIT3	BIT2	BIT1	BIT0									
X4	X3	X2	X1									
F7.19	Output terminal status at current fault	This value is decimal. Show the status of output terminals of most recent fault. The order is shown as follow: <table border="1" style="margin-left: 20px;"> <tr> <td>BIT2</td> <td>BIT1</td> <td>BIT0</td> </tr> <tr> <td>R02</td> <td>R01</td> <td>Y1</td> </tr> </table> If input terminal Y is ON, the corresponding value is 1, while OFF is corresponding to 0. This value can reflect the status of digital output signals	BIT2	BIT1	BIT0	R02	R01	Y1	/	/		
BIT2	BIT1	BIT0										
R02	R01	Y1										

F8 enhanced function

Para. No	Name	Description	Range	Default
F8.00	ACC. Time 2	1.0s~3600.0s	1.0~3600.0	20.0s
F8.01	DEC. time 2	1.0s~3600.0s	1.0~3600.0	20.0s

You can choose acc. and dec. time of F0.08, F0.09 and above three times. Their means are same. Please refer to relative description of F0.08 and F0.09.

Factory acc. and dec. time for 5.5kW and below models is 10.0S, and for 7.5kW to 55kW mode is 20.0s, and for 75kW and above models is 40.0s

Acc. and dec. time 1 (F0.08, F0.09) and time 2 (F8.00, F8.01) can be selected by the

combination of multi-function digital input terminals.

Para. No	Name	Description	Range	Default
F8.02	JOG freq.	0.00~(max. freq.) (F0.04)	0.00~F0.04	5.00Hz
F8.03	JOG acc. time	0.1s~3600.0s	0.1~3600.0	Set by motor
F8.04	JOG dec. time	0.1s~3600.0s	0.1~3600.0	Set by motor

Define the given frequency and acc. /dec. time of frequency converter which is in jog status. Start and stop of Jog running are according to direct starting mode and slowdown mode. Acc time in JOG status refers to the time which need from 0Hz to F0.04. Dec. time in JOG status refers to the time which need from F0.04 to 0Hz.

Factory acc. and dec. time for 5.5kW and below models is 10.0S, and for 7.5kW to 55kW mode is 20.0s, and for 75kW and above models is 40.0s

Para. No	Name	Description	Range	Default
F8.05	Skip freq.	0.00~F0.04 (max. freq.)	0.00~F0.04	0.00Hz
F8.06	Skip freq. bandwidth	0.00~F0.04 (max. freq.)	0.00~F0.04	0.00Hz

If the setting frequency is in the range of hopping frequency, actual running frequency will run at closely border of skip frequency.

Choose FH to avoid mechanical resonance points of load. The frequency converter can set one skip point. If the skip point is 0 this function does not work.

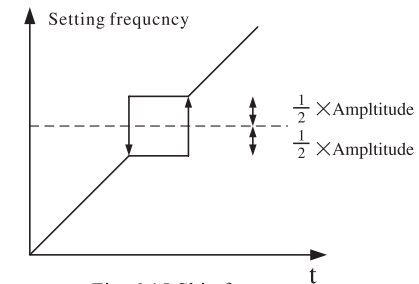

Fig. 6.15 Skip frequency

Para. No	Name	Description	Range	Default
F8.07	Traverse amplitude	0.0% ~ 100.0% (Relative to freq. setpoint)	0.0~100.0	0.0%
F8.08	Jitter freq. amplitude	0.0% ~ 50.0% (Relative to traverse amplitude)	0.0~50.0	0.0%
F8.09	Ramp-up time of traverse	0.1s~3600.0s	0.1~3600.0	5.0s
F8.10	Ramp-down time of traverse	0.1s~3600.0s	0.1~3600.0	5.0s

This function applies to the textile, chemical fiber industry and occasions which

need cross-move and winding function. Traverse frequency refers to the output frequency which is swing around the center frequency of frequency converter. Running frequency is shown as follow. The amplitude is set by F8.07. When F8.07 is equal to zero, traverse frequency does not work.

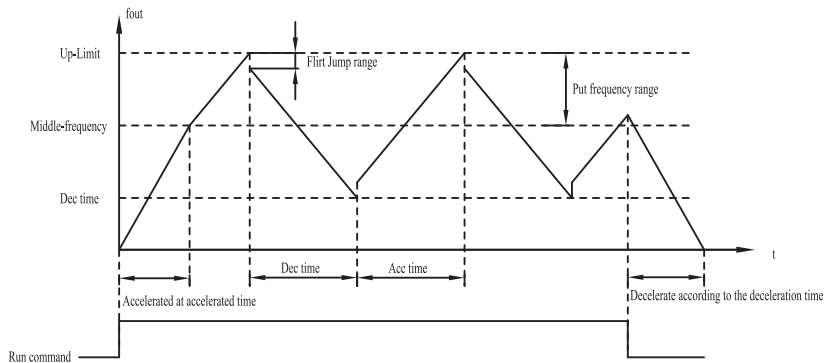

Fig. 6.16 Schematic diagram of traverse frequency

Traverse range: traverse running is limited by upper and lower frequency.

Traverse range relative to the center frequency: traverse range=center frequency ×traverse range F8.07.

Sudden jumping frequency=traverse range×F8.08. when run at traverse frequency, the value which is relative to the sudden jumping frequency

Ramp-up time of traverse: the time taken between the lowest point to the highest point of frequency.

Ramp-down time of traverse: the time taken between the highest point to the lowest point of frequency.

Para. No	Name	Description	Range	Default
F8.11	Fault auto reset times	0~3	0~3	0
F8.12	Auto reset interval	0.1s~100.0s	0.1~100.0	1.0

Auto reset times decide how many times the frequency converter reset it by itself when failed. More than this value the frequency converter standby and awaiting restoration.

Auto reset interval is the time between failures happened and reset.

Para. No	Name	Description	Range	Default
F8.13	FDT level	0.00~F0.04(max. frequency)	0.00~ F0.04	50.00Hz
F8.14	FDT lag	0.0%~100.0% (FDT)	0.0~100.0	5.0%

Set the detected value of output frequency and the delayed value of output action cancel. As shown in following fig.

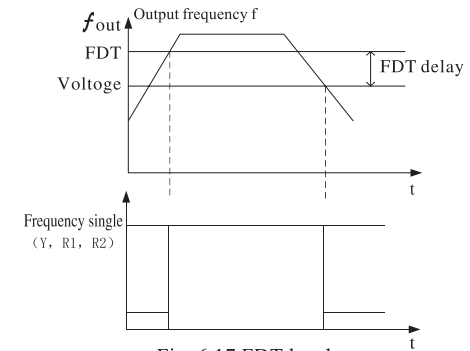

Fig. 6.17 FDT level

Para. No	Name	Description	Range	Default
F8.15	Freq. arrive detecting range	0.0%~100.0% (max. freq.)	0.0~100.0	0.0%

When the output frequency reaches to the setting frequency of frequency converter, this feature can adjust the amplitude of its detection. As shown in follows:

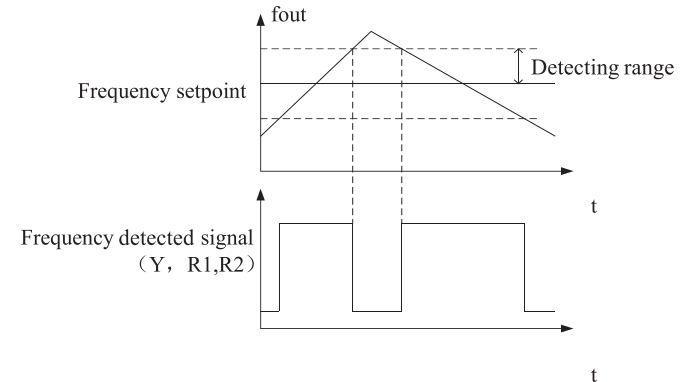

Fig. 6.18 Frequency arrive detecting range

Para. No	Name	Description	Range	Default
F8.16	Brake threshold voltage	115.0%~140.0% (standard DC bus voltage) (380V series)	115.0~140.0	130.0%
		115.0%~140.0% (standard DC bus voltage)	115.0~140.0	120.0%

Para. No	Name	Description	Range	Default
		(220V series)		

The function code is used to set the initial braking bus voltage. 100% relative to standard DC bus voltage. Appropriate adjusting will brake effectively

Para. No	Name	Description	Range	Default
F8.17	Rotational speed display coefficient	0.0%~1000.0%	0.0~1000.0	100.0%

Speed=120*Frequency*F8.17/Motor pole number, this function used to correct the display errors. It has no affect to the actual speed.

F9 PID control group

Set the F0.03 (frequency command selection) to 5 (PID control setting), and the PID controls the running party effectively.

PID is a common method for process control, calculate the amount dispersion of the feedback signal and the target signals in the proportion, integral, differential operation to adjust the output frequency of frequency converter, which constitute a negative feedback system, so the undercontrol amount will be stable compared with the target amount. It is applied to process control, such as flow control, pressure control and temperature control etc. Block diagram of the basic control principles are as follows:

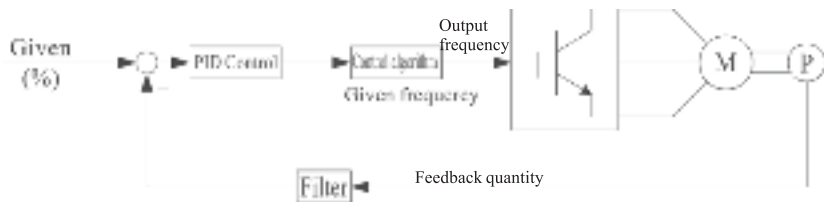
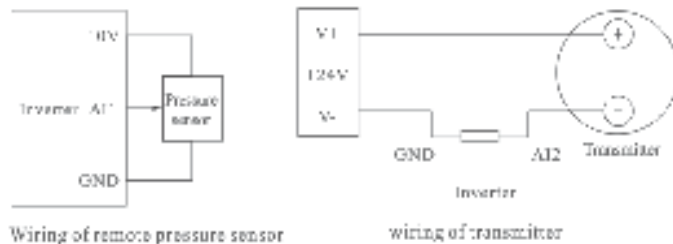

Fig. 6.19 Block diagram of the process PID



Para. No	Name	Description	Range	Default
F9.00	PID source selection	0: Panel (F9.01) 1: AI1 2: AI2 3: Communication 4: Fixed frequency	0~4	0

PID control worked when value of parameter F0.03 is 5. This parameter decides which PID given channel should be used. The target value of PID process is relative value. 100 percent of this value is corresponding to 100 percent of feedback single of controlled system. System has always been based on the relative value (0%~ 100.0%) to calculate.

Note: You can set the parameters of FA group to achieve fixed frequency given.

Para. No	Name	Description	Range	Default
F9.01	Panel PID preset	0.0%~100.0%	0.0~100.0	0.0%

When F9.00 = 0. Reference value of this parameter is the feedback of system.

Para. No	Name	Description	Range	Default
F9.02	PID feedback source selection	0: AI1 feedback 1: AI2 feedback 2: AI1+AI2 feedback 3: Communication feedback	0~3	0

Select PID feedback channel by this parameter

Note: Given channel and feedback channel can not be coincidence, otherwise, PID can not be controlled effectively.

Para. No	Name	Description	Range	Default
F9.03	PID output characteristic	0: Positive 1: Negative	0~1	0

Positive: When the PID feedback signal is greater than the given signal, the output of frequency inverter will decline to make a balance of PID, such as Winding tension, PID control.

Negative: When the feedback signal is greater than the given signal, output of frequency inverter will increase to make a balance PID, such as release of tension control.

Para. No	Name	Description	Range	Default
F9.04	Proportional gain (K)	0.00~100.00	0.00~100.00	1.00
F9.05	Integral time (Ti)	0.01s~10.00s	0.01~10.00	0.10s
F9.06	Differential time (Td)	0.00s~10.00s	0.00~10.00	0.00s

Proportional gain (K): decide the regulating intensity of PID regulator. The greater the K the greater the regulating intensity is. The parameter of 100 refers that, when the deviation of PID feedback and given is 100%, the regulating range of output frequency is maximum frequency (Ignore the integral role and differential role).

Integration time (Ti): decide the adjusting speed of deviation between PID feedback and PID given which is adjusted by PID regulator. When the deviation of FID feedback and PID given is 100%, the integral regulator (ignore the role of the proportion and the role of differential), integration time refers to the time after

adjusting, the adjusting value has reached the maximum frequency (F0.04). The shorter integration time the greater regulating intensity

Differential time (Td): decide of the regulating intensity of deviation between PID feedback and PID given wich is adjusted by PID regulator. Differential time refers the time if the deviation of feedback is 100% in this time, the regulating value is maximum frequency (Ignore the integral role and differential role). The longer the differential time the greater the intensity.

PID process control is a most commonly used control method. The effect of each part is different. A brief description of working principle and regulation approach is shown as follow:

Proportional adjust (P): if there is deviation between the feedback and given, the output is in proportion to the adjusting amount, if the deviation is constant, the adjustment is also constant. The proportional adjusting can response feedback changes quickly, but no dispersion control can not be achieved on by proportion control. The greater the proportional gain, the faster the adjusting. But there may be oscillation if the proportional gain is too large. Regulation method is to set the Ti a very long time, and the differential time is set to zero. Then run the system only with proportional adjusting, and then change the given value to observe the stable deviation between the feedback and given value. If the stable deviation is in the direction of given value(for example, increase given value, after system stable, the feedback value is less than the given value), increase the proportional gain, vice versa. And then repeat the above process until the stable deviation is much little.

Integral time (I): if there is deviation between feedback and given value, increase the output adjusting value until no deviation appears. Integral regulator can effectively eliminate the static error. If the Integral regulator is too intensive there will be repeatedly overregulation. System will be unstable until oscillation.the oscillation charater caused by intensive intergral function: feedback signal is swing up and down, and the swing range gradually increased until the oscillation. Integration time often ajust from large to small. Integration time shall be adjust gradually to make the system stable.

Differential time (D): if the deviation of feedback and given value changes, output is in proportion to deviation. This adjusting value only has relation to the direction and value of deviation changed. But has nothing to do with deviation value. The effect of differential adjusting is to restrain the changes of feedback signal. Differential regulator is used with caution, because differential adjusting will amplify system interference easily. in particular in higher frequency changing.

Para. No	Name	Description	Range	Default
F9.07	Sampling cycle (T)	0.01s~100.00s	0.01~100.00	0.10s
F9.08	PID deviation limit	0.0%~100.0%	0.0~100.0	0.0%

Sampling period (T): refers to the sampling period of feedback. Regulator operates one time in each sampling cycle. The longer the sampling period, the slower the response speed.

PID control deviation limit: PID output value is corresponding to the maximum

allowable deviation of closed-loop given value, as shown in following fig., within the limits of the deviation, PID regulator stops regulating. Reasonable setting of this function code can adjust the accuracy and stability of PID system.

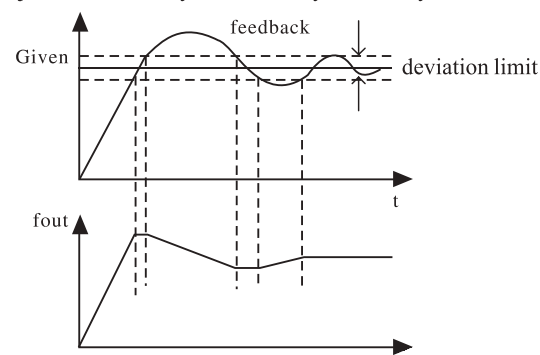

PID deviation limit and output frequency

Para. No	Name	Description	Range	Default
F9.09	PID feedback lost detecting value	0.0%~100.0%	0.0~100.0	0.0%
F9.10	PID feedback lost detecting time	0.0s~3600.0s	0.0~3600.0	10.0s

PID feedback lost detecting value: this detected value is corresponding to the full-scale (100%), the system has been detecting the PID feedback value, when the feedback value is less than or equal to the value of feedback disconnection detection, system begins to record time. When the detected time exceeds F9.10, the system will report a PID feedback fault (PIDE).

Para. No	Name	Description	Range	Default
F9.11	Pump sleep enable	0~3	0~3	0
F9.12	Delay time	0s ~3600.0s	0~3600.0	60.0s
F9.13	Awake pressure	0%~1000.0%	0~100.0	80.0%
F9.14	Speed/current limit	0%~100.0%	0~100.0	50%

Pump sleep mode :

0: Closed, has no sleeping function, default mode.

1: Flux switch, if the sleep switch connects, it enters into sleeping delay, otherwise sleep mode dose work.

2: Speed mode, if output frequency is less than the sleeping frequency, it enters into sleeping delay, otherwise sleep mode dose work.

3: Current mode, if output current is less than the sleeping current, it enters into sleeping delay, otherwise sleep mode dose work.

Note:

1. The pump sleep function is only effective when the PID close-loop control is valid.

2. When this function works, the motor may be instantaneous rotating. Please be careful to make sure the sudden start will not cause device damage or human injury
 Delay time: begin to delay if it meets the sleeping condition, if still meet the sleeping condition after delay, the frequency converter will enter into sleep status. Its output frequency is 0.

Wake pressure: in sleep mode, if feedback pressure is less than the wake pressure, it will exit sleep status.

Speed/current limit of sleep: in speed mode, if output frequency is less than sleep frequency (sleep frequency= motor rated frequency*this limit/100). In current mode, if output current is less than sleep current (sleep current = motor rated current *this limit/100). It will enter into sleep mode (When F0.03 is set to 5).

FA Fixed frequency control group

Set the F0.03 (frequency command selection) to 4 (multi segment speed setting), and the multi segment speed operation is valid.

Para. No	Name	Description	Range	Default
FA.00	Fixed frequency (FF) control method	0~3	0~3	0

0: controlled by terminals. Given frequency of multi-speed is decided by terminal status.

1: controlled by time, stop running after last speed.

2: controlled by time, after last speed, it will run at last speed.

3: controlled by time, after last speed, it will run at the beginning speed and circulate.

Para. No	Name	Description	Range	Default
FA.01	FF0	-100.0%~100.0%	-100.0~100.0	0.0%
FA.02	FF1	-100.0%~100.0%	-100.0~100.0	0.0%
FA.03	FF2	-100.0%~100.0%	-100.0~100.0	0.0%
FA.04	FF3	-100.0%~100.0%	-100.0~100.0	0.0%
FA.05	FF4	-100.0%~100.0%	-100.0~100.0	0.0%
FA.06	FF5	-100.0%~100.0%	-100.0~100.0	0.0%
FA.07	FF6	-100.0%~100.0%	-100.0~100.0	0.0%
FA.08	FF7	-100.0%~100.0%	-100.0~100.0	0.0%

Description: The symbol of parameter decides the direction of motor. If the symbol is negative, motor is reversing. 100.0% relative to maximum frequency.

When FA.00=0,X1=X2=X3=OFF, frequency input method is decided by parameter F0.03.

If any one of X1, X2, and X3 is not OFF, the frequency converter in the fixed frequency control mode, fixed-frequency priority is higher than the keyboard, analog, and communications. You can get less than 8-fixed frequency with X1, X2, X3 terminals.

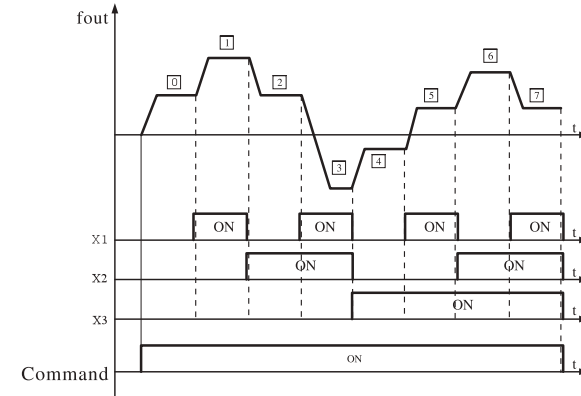

Fig. 6.23 logic diagram of multi-speed running

The control mode like Start/Stop of fixed-frequency is also decided by parameter F0.01. The relationship between fixed-frequency section and X1, X2, X3 is shown as follow.

X1	0	1	2	3	4	5	6	7
X2	0	0	0	0	0	0	0	0
X3	0	0	0	0	0	0	0	0
section	0	1	2	3	4	5	6	7

Fig. 6.24 The relationship between fixed-frequency section and X1, X2, X3

Para. No	Name	Description	Range	Default
FA.09	FF running time 0	0.0s~3600.0s	0.0~3600.0	1.0s
FA.10	FF running time 1	0.0s~3600.0s	0.0~3600.0	1.0s
FA.11	FF running time 2	0.0s~3600.0s	0.0~3600.0	1.0s
FA.12	FF running time 3	0.0s~3600.0s	0.0~3600.0	1.0s
FA.13	FF running time 4	0.0s~3600.0s	0.0~3600.0	1.0s
FA.14	FF running time 5	0.0s~3600.0s	0.0~3600.0	1.0s
FA.15	FF running time 6	0.0s~3600.0s	0.0~3600.0	1.0s
FA.16	FF running time 7	0.0s~3600.0s	0.0~3600.0	1.0s

When FA.00 is not 0, these time are effective. The final given frequency is decided

by respective time of fixed-frequency. If any fixed-frequency is not needed, it can be set to 0. Every segment time is responding to each fixed-frequency setting.

Fb protection function group

Para. No	Name	Description	Range	Default
Fb.00	Motor over-load protection	0: Disabled 1: Normal motor (with low speed compensation) 2: Variable frequency motor (without low speed compensation)	0~2	2

0: No protection. Has no overload protection (use with cautions), the frequency converter can't protect the motor in this condition.

1: Normal motor (with low speed compensation). The cooling effect of normal motor is bad when motor in low speed status, so it's need to adjust electronic thermal protection value that refers to low speed compensation.

2: Frequency converter motor (without low compensation). The cooling effect of motor does not change with speed changing, so it doesn't need low compensation.

Para. No	Name	Description	Range	Default
Fb.01	Motor over-load protecting current	20.0%~120.0%	20.0~120.0	100.0%

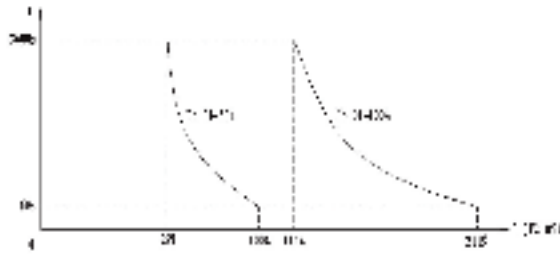

Fig. 6.25 Coefficient settings of motor overload protection

This value is determined by the following formula:

Motor overload protection current = (Maximum load current / frequency converter rated current)* 100%. Generally, the maximum load current is equal to the motor rated current. When the rated current value of load motor does not match the rated current value of frequency converter, motor overload protection value can be achieved by setting the parameter of Fb.00 ~ Fb.01.

Para. No	Name	Description	Range	Default
Fb.02	Threshold of trip-free	70.0% ~ 110.0% (standard DC bus voltage)	70.0~110.0	80.0%
Fb.03	Decrease rate of trip-free	0.00Hz~F0.04 (max. freq.)	0.00~F0.04	0.00Hz

If decrease rate of trip-free is set to 0, the instantaneous restart power-down function is invalid.

Threshold of trip-free: When the DC voltage less than this point, the frequency converter began to decline its output frequency, and the motor in generate power status, feedback power to remain the frequency converter continue to work until powered on again.

Note: Adjust these two parameters properly, you can achieve a good grid switching, and the frequency converter will not stop caused by protection.

Para. No	Name	Description	Range	Default
Fb.04	Overvoltage stall protection	0: Disabled 1: Enable	0~1	1
Fb.05	Overvoltage stall protecting voltage	110% ~ 140% (standard DC bus voltage) (380V series)	110~150	140%
		110% ~ 140% (standard DC bus voltage) (220V series)	110~150	115%

When Frequency converter decelerates, due to the impact of the load inertia, actual decline rate if motor speed may be lower than the decline rate of output frequency, at this time, the motor will return power to the frequency converter which is caused by DC bus voltage rising; If no measures are taken, it will lead to trip which is caused by bus over-voltage. Over-voltage stall protection detects the bus voltage and compares it with over-voltage stall point defined by standard bus voltage Fb.05. if it is exceed over-voltage stall point, the output frequency of frequency converter will stop declining. If the next detected voltage is below over-voltage stall point, the frequency converter will decelerate continually, as shown in the following Figure:

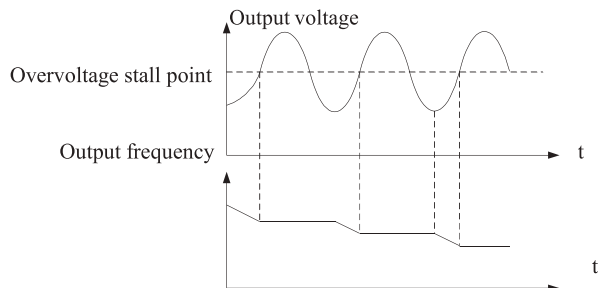

Fig. 6.26 Overvoltage stall protection

Para. No	Name	Description	Range	Default
Fb.06	Auto current limiting threshold	100%~200%	100~200	T type:150% P type:120%
Fb.07	Reversed	/	/	/

FC serial communication group

Para. No	Name	Description	Range	Default
FC.00	Local address	0 ~ 31, 0: broadcast address	0~247	1

When the host is in the preparation of the frame, address 0 is the radio address, all machines on MODBUS can accept the frame, but no machine can answer.

Note: address of machine can not be set 0.

Address must be unique in the local communications network. It's the base of point-to-point communication for frequency converter and host device.

Para. No	Name	Description	Range	Default
FC.01	Baud rate selection	0: 1200bps 1: 2400bps 2: 4800bps 3: 9600bps 4: 19200bps 5: 38400bps	0~5	3

This parameter is used to set the data transfer rate between frequency converter and PC. Note that the baud rate of host computer and frequency converter must be same, otherwise, communication is impossible. The greater the baud rate, the faster the communication is.

Para. No	Name	Description	Range	Default
FC.02	Data format	0: No check (N, 8, 1) for RTU 1: Even check (E, 8, 1) for RTU	0~17	0

Para. No	Name	Description	Range	Default
		2: Odd check (O, 8, 1) for RTU 3: No check (N, 8, 2) for RTU 4: Even check (E, 8, 2) for RTU 5: Odd check (O, 8, 2) for RTU 6: No check (N, 7, 1) for ASCII 7: Even check (E, 7, 1) for ASCII 8: Odd check (O, 7, 1) for ASCII 9: No check (N, 7, 2) for ASCII 10: Even check (E, 7, 2) for ASCII 11: Odd check (O, 7, 2) for ASCII 12: No check (N, 8, 1) for ASCII 13: Even check (E, 8, 1) for ASCII 14: Odd check (O, 8, 1) for ASCII 15: No check (N, 8, 2) for ASCII 16: Even check (E, 8, 2) for ASCII 17: Odd check (O, 8, 2) for ASCII		

Data format of host computer and frequency converter must be consistent, otherwise communication is impossible

11-bits(for RTU)

Data format: 8-N-2

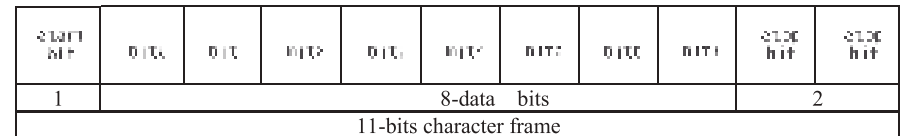

Data format: 8-E-1

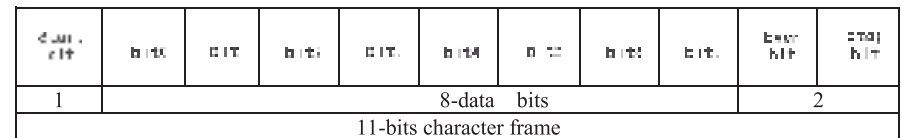

Data format: 8-0-1

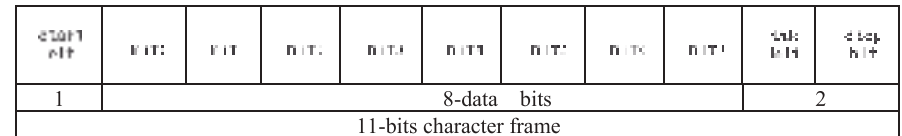

10-bits(for ASCII)

Data format: 7-N-2

Start bit	Bit 7	Bit 6	Bit 5	Bit 4	Bit 3	Bit 2	Bit 1	Stop bit	End bit
1	7-data bits							2	
10-bits character frame									

Data format: 7-B-1

Start bit	Bit 7	Bit 6	Bit 5	Bit 4	Bit 3	Bit 2	Bit 1	Stop bit	End bit
1	7-data bits							2	
10-bits character frame									

Data format: 7-0-1

Start bit	Bit 7	Bit 6	Bit 5	Bit 4	Bit 3	Bit 2	Bit 1	Stop bit	End bit
1	7-data bits							2	
10-bits character frame									

Para. No	Name	Description	Range	Default
FC.03	Communication respond delay time	0ms~200ms	0~200	5ms

Communication response delay indicates the interval time between receiving the data and sending response. If response time is less than the dealing time of system, the response delay refers to the dealing time of system. If response time is more than the dealing time of system, after the system complete process, it is necessary to wait for delay time, and then send data to computer.

Para. No	Name	Description	Range	Default
FC.04	Communication timeout	0.0s (invalid), 0.1~100.0s	0~100.0	0.0s

If value of parameter is 0.0s, the communications timeout parameter is invalid.

When the function code is set to RMS, if the time between current communication and next communication exceeds communication overtime, the system will report communication fault error (CE).

Generally, it is set to be null and void. If continuous communications systems, meeting the parameters set, you can monitor the status of communications.

Para. No	Name	Description	Range	Default
FC.05	Communication error action	0: Alarm and electrical stop 1: No alarm and continue to run 2: No alarm but stop according	0~3	1

		to F1.05 (only valid in communication control) 3: No alarm but stop according to F1.05 (under all control)		
--	--	---	--	--

Frequency converter can continue to work by set protections in order to shield error and stop when abnormal exit in communication.

Para. No	Name	Description	Range	Default
FC.06	Response action	0: Response to writing 1: No response to writing	0~1	0

When the value is set to 0, the frequency converter has response to both read and write commands of the host computer.

When the function code is set to 1, the frequency converter only has response to read commands of the host computer, and has no response to write command. The communication efficiency can be improved by this method.

Fd supplementary function group

Para. No	Name	Description	Range	Default
Fd.00	Oscillation suppression low-frequency threshold	0~500	0~500	5
Fd.01	Oscillation suppression high-frequency threshold	0~500	0~500	100

However, the majority of motors operating in certain frequency bands will appear current shock, motor may operate unstable, even will lead over-current. When Fd.04 = 0 it can suppress the oscillation. If Fd.00, Fd.01 is smaller, the effect of oscillation suppression and current increasing will be more obvious. If Fd.00, Fd.01 is larger, the effect of oscillation suppression will be unobvious.

Para. No	Name	Description	Range	Default
Fd.02	Oscillation suppression amplitude limit	0~10000	0~10000	5000

Large voltage rising can be suppressed by setting parameter of Fd.02.

Para. No	Name	Description	Range	Default
Fd.03	Oscillation suppression high and low frequency deviding boundaries	0.00Hz~F0.04 (max. freq.)	0.00Hz~F0.04	12.50Hz

Fd.03 is the boundary of Fd.00 and Fd.01

Para. No	Name	Description	Range	Default
Fd.04	Oscillation suppression	0: Enabled 1: Disabled	0~1	1

0: Enabled

1: Disabled

Oscillation suppression is focus to V/F control. General motors with no-load or light load often have current shock that will lead to an abnormal running of motor or even over-current. When Fd.04 = 0 it can suppress the oscillation. Frequency converter will suppress the oscillation according to the parameter of Fd.00~Fd.03.

Para. No	Name	Description	Range	Default
Fd.05	PWM mode selection	0: PWM mode 1 1: PWM mode 2	0~1	0

0: PWM mode 1, the model is a normal PWM mode. Electrical noise is smaller at low-frequency, while electrical noise is larger at high-frequency.

1: PWM mode 2, the electrical noise is smaller in the mode but temperature rising is high. If you choose this function, the frequency converter shall be used with derating.

Para. No	Name	Description	Range	Default
Fd.06	Reversed	/	/	/
Fd.07	Reversed	/	/	/
Fd.08	Reversed	/	/	/
Fd.09	Reversed	/	/	/

FE factory parameter group

This group parameters are the factory parameters, the user shall not attempt to open these parameters, otherwise, will cause abnormal or damage of the frequency converter

Chapter 7 Fault check and handling

7.1 List of Fault and Warning Messages

Fault code	Fault type	Possible Reason	Solution
OUT1	IGBT fault	1. Acc. time too short 2. IGBT module fault 3. Caused by interference. 4. grounding not properly 5. frequency converter instantaneous over-current 6. short circuit between U,V,W or ground	1. increase acc. time 2. ask for support 3. inspect external equipment if there are interference source 4. check output cable
P.OFF	DC voltage detect fault	1. DC voltage detect circuit fault 2. grid voltage too low	1. ask for support 2. check external grid and repair
OC1	Over-current when acceleration	1. acc. time too short 2. grid voltage too low 3. frequency converter power too low	1. increase acc. time 2. check input power 3. select bigger capacity inverter
OC2	Over-current when deceleration	1. Dec. time too short 2. torque of load inertia big 3. frequency converter power lower	1. increase dec. time 2. add proper energy consumption braking compents 3. select bigger capacity inverter
OC3	Over-current at constant speed	1. load transients or abnormal 2. grid voltage low 3. frequency converter power low	1. check load or reduce transient of load 2. check input power 3. select bigger capacity inverter
OV1	Over-voltage when acceleration	1. input voltage abnormal 2. restart the rotational motor after sudden shut off	1. check input voltage 2. avoid restart-up after stop
OV2	Over-voltage when deceleration	1. dec time too short 2. load inertia large 3. input voltage abnormal	1. increase dec. time 2. increase energy-consuming components 3. check input voltage
OV3	Over-voltage at constant speed	1. input voltage changes abnormal 2. load inertia large	1. install input reactor 2. add proper energy consumption braking compents
UV	DC bus under voltage	1. grid voltage low	1. check grid input voltage
OL1	Motor overload	1. grid voltage too low 2. rated current set incorrect 3. motor stall or load transients too strong 4. motor power too big	1. check grid voltage 2. reset motor rated current 3. check load and adjust torque lift 4. select proper motor
OL2	Frequency converter	1. acc. too fast 2. restart the rotational motor	1. increase acc. time 2. avoid restart after stop

Fault code	Fault type	Possible Reason	Solution
	overload	3. grid voltage too low 4. load too large	3. check grid voltage 4. select bigger capacity inverter
OH2	Over-heat (>85°C)	1. air duct jam or fan damage 2. ambient temperature too high 3. wiring or connectors on control board loose 4. auxiliary supply damage, drive under-voltage 5. bridge arm of power module switched on 6. control board abnormal	1. dredge air channel or change fan 2. reduce ambient temperature 3. check and reconnect 4. ask for support 5. ask for support 6. ask for support
EF	External fault	1. Xi external fault input terminal acts	1. check external device input
CE	Communication fault	1. The miset of the baud rate 2. Communication error using serial communication 3. Long communication interruption	1. Set up a reasonable baud rate 2. Reset by the STOP key. Seek service 3. Check the communication interface wiring
ItE	Current detect circuit fault	1. connector on control board connects not good 2. control power supply broken 3. hoare components broken 4. amplifier circuit abnormal	1. check connector, rewire 2. ask for support 3. ask for support 4. ask for support
TE	Motor identification fault	1. motor capacity and frequency converter capacity not match 2. motor rated parameter set incorrect 3. the offset between detected parameter and standard parameter too huge 4. identification overtime	1. change frequency converter model 2. set rated parameters according to motor nameplate 3. empty the motor and identify again 4. check motor cable and parameters
EEP	EEPROM fault	1. write and read of control parameters error 2. EEPROM damaged	1. press STOP key to reset, or ask for support 2. ask for support
PL	Input open-phase	1. Input cables of R, S, T open-phase	1. check input power supply 2. check cables
SPO	Output open-phase	2. output cable of U, V, W open phase or unbalance	1. check output cable 2. check motor and cable
PIDE	PID feedback fault	1. PID feedback offline 2. PID feedback source disappear	1. check PID feedback signal wire 2. check PID feedback source

7.2 Common fault and solutions

Frequency converter may have following faults during operation, please refer to the following solutions:

Fault	Solutions
No display after powered on	Inspect whether the voltage of power supply is the same with frequency converter rated voltage with multi-meter. If power supply has problem, please check and solve it.
	Inspect whether three-phase rectify bridge is in good condition or not. If not, ask for support.
	Check LED lamp. If it is off, the fault is mainly focus on rectify bridge or buffer resistor. If it is on, the fault may be in switching power supply. Please ask for support.
Power supply air switch trips open when powered on	Inspect whether input power supply is grounded or short circuit. Please solve the problem.
	Inspect whether rectify bridge has been burnt out. If it is damaged, ask for support.
Motor does not rotate after frequency converter running	Inspect whether the three phases output among U, V and W is balance. If it is balance, motor may be damaged or mechanically locked. Please solve it.
	If there is output but the three phases is not balance, in general, drive board or output module is damaged, please ask for support.
	If there is not output, drive board or output module may be damaged, please ask for support.
Frequency converter display normally when powered on, but power switch trips after running	Inspect whether the output side of frequency converter is short circuit, if yes, ask for support.
	Inspect whether ground fault exists. If yes, solve it.
	If trip happens occasionally and the distance between motor and frequency converter is too far, it is recommended to install output AC reactor.

Chapter 8 Maintenance and Inspection

Warning

1. Maintenance must be performed according to designated maintenance method
2. Maintenance must be performed only by certified person
3. After cutting off the power supply, wait for 10min, maintenance work is allowed to carry out.
4. Do not directly touch components on PCB board. Otherwise the frequency converter may be damaged by electrostatic discharge.
5. After maintenance, all screws must be tightened.

8.1 Daily maintenance

In order to prevent the fault and make it operate smoothly in high-performance for a long time. Maintenance work must be performed periodically.

Checking item	Content
Temperature /humidity	Ensure ambient temperature is among -10°C~40°C and humidity is less than 90%
Oil mist and dust	Ensure that there is no oil mist or condensation in the frequency converter
Frequency converter	Ensure there is no abnormal heating and vibration to frequency converter
Fan	Ensure the fans rotate normally and have no foreign object
Input power supply	Ensure voltage and frequency is within the allowed range
Motor	Ensure there is no abnormal vibration, heat and open-phase

8.2 Periodic maintenance

Customer should check frequency converter every 6 months to prevent frequency converter fault and ensure high-performance and stable operation

Checking item	Content	Solve method
Screws of external terminals	Check if the screw is loose or not	Tight up
PCB board	Dust and dirtiness	Clear with dry compressed air
Fan	Check if there is abnormal noise or vibration or the accumulative ime exceeds 20000 hours	1. clear sundries 2. change the fan
Electrolytic capacitance	Check if the color is changed and if there is smelly scent.	Replace electrolytic capacitance

Heat sink	Dust and dirtiness	Clear with dry compressed air
Power components	Dust and dirtiness	Clear with dry compressed air

8.3 Wearing parts replacement

Fans and electrolytic capacitor are wearing parts. Please make periodic replacement to ensure long term, safety and failure-free operation. Replacement periods are as follows:

- ◆ Fan: Must be replaced when using up to 20000h;
- ◆ Electrolytic capacitor: Must be replaced when using up to 30000h~40000h

8.4 Frequency converter storage

For temporary storage and long-term storage the following points are remembered after purchase:

1. Frequency converter should be stored in a room with good ventilation and kept away from high temperature, moisture and metal dust.
2. Electrolytic capacitor may be degraded after a long time storage, so the frequency converter must be powered on at least every two years for 5 hours. Input voltage must slowly rise to rated value by voltage regulator.

Chapter 9 RS485 Communication

Frequency converter has RS485 communication interface; it can achieve Master-Slave communication by using international standard ModBus protocol. Users can achieve centralized control (frequency converter command setting, frequency setting, parameters modifying, frequency converter status and fault information monitoring, etc.) by PC/PLC, industrial PC to meet specific application requirements.

9.1 Protocol

Modbus serial communication protocol defines the frame and format of Asynchronous serial communication. Include: Master polling and broadcast frames, format of the slave response frame; the frame from Master include: slave address (or broadcast address), command, data and error checking and so on. Response from Slave in same structure, including action confirmed that the return of data and error checking and so on. If an error occurs when the Slave received signal from Master, or can not complete the action requested by Master, slave will respond a fault frame to the Master.

9.2 Application

NVF2 series frequency converter accesses the "single-master and multi-slave" control network with RS232/RS485 bus.

9.3 Bus Architecture

1. Interface mode: RS485 hardware interface
2. Transport mode: Asynchronous serial, half-duplex transmission
At the same time, master and slave can only have one to send data and another to receive data. Data in the process of serial asynchronous communication is the form of message, sent one by one.
3. Topology: Single-master and multi-slave system. Slave address setting range is 1 ~ 247, 0 address for broadcasting address. Every address must be unique in network to ensure the normal ModBus communication
4. In order to avoid signal interference, the communication connection is recommended to avoid the use of shielded twisted pair line, parallel line. If the bus is long, be sure to shield each node GND to the shielded twisted pair line

9.4 Protocol Description

Communication protocol of the frequency converter is a master-slave asynchronous serial ModBus communication protocol. There is only one network device (Master) can establish an agreement (called "query / command"). Other equipment (Slave)

can only respond to the Master's "query / command", or make the corresponding action under the Master's "query / command". The Master can be personal computer (PC), industrial control equipment or programmable logic controller (PLC) and so on. The Master can communicate with a special Slave; it can also broadcast messages to all devices on line. For a separate visit to the host "query / order", the Slave must return a message (called response); for the broadcast messages of the Master, the Slave doesn't need feedback information

9.5 Modbus message frame

Data format of The ModBus protocol is divided into RTU (Remote Terminal Unit) mode and ASCII (American Standard Code for Information International Interchange) mode.

RTU mode, each byte format is as follows: an 8-bit binary, hexadecimal 0 ~ 9, A ~ F, for each frame of eight domains, consists of two hexadecimal characters.

ASCII mode, each byte format is as follows:

Coding system: communication protocol is hexadecimal. The meaning of ASCII information characters: "0" ... "9", "A" ... "F" on behalf of each of hexadecimal ASCII information, such as:

Byte	'0'	'1'	'2'	'3'	'4'	'5'	'6'	'7'	'8'	'9'
ASCII	0x30	0x31	0x32	0x33	0x34	0x35	0x36	0x37	0x38	0x39
Byte	'A'	'B'	'C'	'D'	'E'	'F'				
ASCII	0x41	0x42	0x43	0x44	0x45	0x46				

Bit of byte: Include the start bit, 7 or 8 data bits, parity bit and stop bit. Bit description is shown as the following table:

11-bit frame:

Start byte	Bit1	Bit2	Bit3	Bit4	Bit5	Bit6	Bit7	Bit8	No parity bit even parity bit odd parity bit	Stop bit
------------	------	------	------	------	------	------	------	------	--	----------

10-bit frame:

Start byte	Bit1	Bit2	Bit3	Bit4	Bit5	Bit6	Bit7	No parity bit even parity bit odd parity bit	Stop bit
------------	------	------	------	------	------	------	------	--	----------

In RTU mode, new frame is always at least 3.5 bytes transmission time of silence, as a start. Baud rate calculation in network transfer rate, 3.5 bytes transmission time can easily get. Followed by transmission of data field as follows: Slave address,

command code, data and CRC check code, each domain transmission is hexadecimal byte 0 ... 9, A ... F. Network equipment always monitors the activities of the communication bus, even in silent time interval. When receiving the first domain (address information), one equipment in network will confirm all of bytes. With the last byte of transfer completed, a similar period of 3.5 byte transmission time interval, used to form knowledge of the end of frame, after which a new frame will begin transmission.

RTU frame format

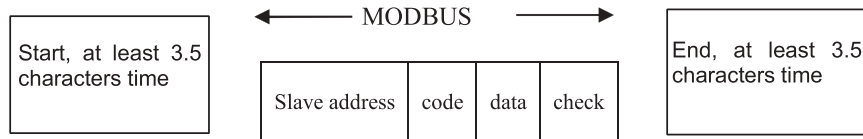

RTU standard frame structure:

A frame of information must be a continuous data stream, if there is interval time more than 1.5 byte in the entire frame transmission before the end, the receiving device will be the removal this incomplete information and erroneous view that the next byte is the address of the new domain a part of the same, if the beginning of a new frame and the previous frame interval time of less than 3.5 bytes time, the receiving device will consider it is a continuation of the former. Because of the disorder of frame, CRC code became incorrect, resulting in communication failure

RTU standard frame structure:

START	T1-T2-T3-T4(3.5 characters time)
Slave ADDR	Communication address: 0~247(Decimal) (0 is Broadcast address)
CMD	03H: read slave parameters 06H: write slave parameters
DATA (N-1) ... DATA (0)	2 * N bytes of data, this is the main part of communication, also the core part of data exchange in communication.
CRC CHK Lo.	Detection value: CRC checksum (16BIT)
CRC CHK Hi.	
END	T1-T2-T3-T4(3.5 characters time)

In ASCII mode, the header of frame is ":" ("0x3A"), the default frame for the end is "CRLF" ("0x0D" "0x0A"). In ASCII mode, except the frame header and tail, other data bytes are sent in ASCII code; first send 4-high, then send 4-low. In ASCII mode, data length is 7 or 8. If data is 'A' ~ 'F', send the data in capital letters of the ASCII code. LRC check the data at this time, ranging from calibration to data from the local address part of the information. Calibration and validation of data equivalent to all those involved in the characters and (give-up binary bits) of the complement.

ASCII frame format

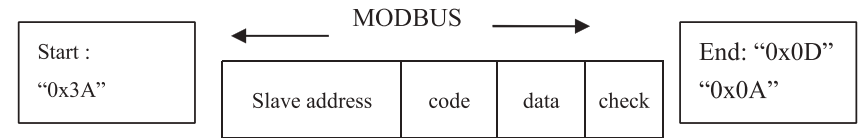

If the MODBUS communication instruction is used to set the inverter to 25.00Hz. Send and write command:

01 06 20 00 13 88 8f 5c
 Inverter converter address Write instructions Function code Data content CRC check code

ASCII standard frame structure

START	': ' (0x3A)
Address Hi	Address: 8-bit address is the combination of 2 ASCII codes
Address Lo	
Function Hi	Code: 8-bit address is the combination of 2 ASCII codes
Function Lo	
DATA(N-1) ... DATA(0)	Data: nx8-bit data is the combination of 2n ASCII codes. If n<=16, the most is 32 ASCII
LRC CHK Lo	LRC check: 8-bit check code is the combination of 2ASCII
LRC CHK Hi	
END Hi	End: END Hi=CR(0x0D), END Lo=LF(0x0A)
END Lo	

9.6 Command code and communications data

9.6.1 Command: 03H (0000 0011) . Read N words (Word) (up to 16 consecutive words). Eg: Read two consecutive words from frequency converter, the slave address is 01H and the memory start address is 0004H. As follows

RTU Master Command

START	T1-T2-T3-T4(3.5 characters time)
ADDR	01H
CMD	03H
Start address Hi.	00H
Start address Lo.	04H
Data number Hi.	00H
Data number Lo.	02H
CRC CHK Lo.	85H
CRC CHK Hi.	CAH
END	T1-T2-T3-T4(3.5 characters time)

RTU Slave Response

START	T1-T2-T3-T4(3.5 characters time)
ADDR	01H
CMD	03H
Byte number	04H
Data address 0004H Hi.	13H

NVF2G series frequency converter

Data address 0004H Lo.	88H
Data address 0005H Hi.	13H
Data address 0005H Lo.	88H
CRC CHK Lo.	73H
CRC CHK Hi.	CBH
END	T1-T2-T3-T4(3.5 characters time)

ASCII Master Command

START	‘: ’
ADDR	‘0’
	‘1’
CMD	‘0’
	‘3’
Start address Hi.	‘0’
	‘0’
Start address Lo.	‘0’
	‘4’
Data number Hi.	‘0’
	‘0’
Data number Lo.	‘0’
	‘2’

ASCII Slave response

START	‘: ’
ADDR	‘0’
	‘1’
CMD	‘0’
	‘3’
Byte number	‘0’
	‘4’
Data address 0004H Hi.	‘0’
Data address 0004H Lo.	‘0’
Data address 0005H Hi.	‘0’
Data address 0005H Lo.	‘0’
LRC CHK Hi	‘F’
LRC CHK Lo	‘6’
END Lo	CR
END Hi	LF

NVF2G series frequency converter

LRC CHK Lo	‘F’
LRC CHK Hi	‘6’
END Lo	CR
END Hi	LF

9.6.2 Command: 06H (0000 0110) write a word. Eg. Write 5000 (1388H) to address 0008H of frequency converter whose slave address is 02H. As follows:

RTU Master Command

START	T1-T2-T3-T4(3.5 characters time)
ADDR	02H
CMD	06H
Write data address Hi.	00H
Write data address Lo.	08H
Data Hi.	13H
Data Lo.	88H
CRC CHK Lo.	05H
CRC CHK Hi.	6DH
END	T1-T2-T3-T4(3.5 characters time)

RTU Slave Response

START	T1-T2-T3-T4(3.5 characters time)
ADDR	02H
CMD	06H
Write data address Hi.	00H
Write data address Lo.	08H
Data Hi.	13H
Data Lo.	88H
CRC CHK Lo.	05H
CRC CHK Hi.	6DH
END	T1-T2-T3-T4(3.5 characters time)

ASCII Master Command

START	‘: ’
ADDR	‘0’
	‘2’
CMD	‘0’
	‘6’
Write data address Hi.	‘0’
	‘0’
Write data address Lo.	‘0’
	‘8’

Data Hi.	'1'
	'3'
Data Lo.	'8'
	'8'
LRC CHK Hi	'5'
LRC CHK Lo	'5'
END Lo	CR
END Hi	LF

ASCII Master Command

START	‘: ’
ADDR	'0'
	'2'
CMD	'0'
	'6'
Write data address Hi.	'0'
	'0'
Write data address Lo.	'0'
	'8'
Data Hi.	'1'
	'3'
Data Lo.	'8'
	'8'
LRC CHK Hi	'5'
LRC CHK Lo	'5'
END Lo	CR
END Hi	LF

ASCII Slave Response

START	‘: ’
ADDR	'0'
	'2'
CMD	'0'
	'6'
Write data address Hi.	'0'
	'0'
Write data address Lo.	'0'
	'8'
Data Hi.	'1'
	'3'
Data Lo.	'8'
	'8'

LRC CHK Hi	'5'
LRC CHK Lo	'5'
END Lo	CR
END Hi	LF

9.7 Frame error check

The error Check of frame mainly consists of two parts, the byte check (odd / even parity) and the entire data frame check (CRC or LRC check).

1. Byte check

The user byte can choose a different check-bit mode, you also can choose not to check, but this will affect the parity bit of each byte setting.

Even check: Add a parity bit before the data transport to represent the sum of "1" in data is odd or even. If the sum of "1" is even, this bit is "0", otherwise, set to "1".

Odd check: Add a parity bit before the data transport to represent the sum of "1" in data is odd or even. If the sum of "1" is odd, this bit is "0", otherwise, set to "1".

For example, data is "1100111", the data contains five "1", If even parity, the parity bit is "1", If odd parity, the odd parity bit is "0", transmit the data, the calculated parity bit parity bit on the frame position, the receiving device must carry on parity, if we find the parity of received data is inconsistent with the preset, but just thought communication error has occurred.

2. Cyclical Redundancy Check

The format of RTU includes CRC calculation and CRC error detection field. CRC field tested the contents of the entire frame. CRC field is two bytes, including 16-bit binary value. It is calculated by adding transmission equipment to the frame. Recalculation of the receiving device received the frame CRC, and received CRC value domain, if the two CRC values are not equal, then an error transmission.

CRC is the first deposit 0xFFFF, then the process will call a frame of six or more consecutive bytes with the current value of register for processing. Only characters in each of the CRC effective 8Bit data, start bit and stop bits and parity bit are invalid.

Generate CRC, each 8-bit characters are alone and register the contents of different or (XOR), the results of least significant bit to move MSB to 0 to fill. Detection of LSB was extracted, if the LSB for 1, register a separate and different preset value or, if the LSB is 0, not carried out. Repeat the whole process 8 times. In the last one (No. 8) after the completion of an 8-bit byte register and a separate and different from the current value or. The value of the final register is the frame that is all of the bytes after the CRC value of the implementation. This CRC calculation is based on international standards and laws of CRC checksum, CRC algorithm users to edit, you can refer to the relevant standard CRC algorithm, the preparation of a truly meet the requirements of the CRC calculation.

There is a simple reference function of CRC calculation (using C programming language):

```

unsigned int crc_cal_value(unsigned char
*data_value,unsigned char data_length)
{
int i;
unsigned int crc_value=0xffff;
while(data_length--)
{
crc_value^=*data_value++;
for(i=0;i<8;i++)
{
if(crc_value&0x0001)crc_value=(crc_value>>1)^0xa001;
else crc_value=crc_value>>1;
}
}
return(crc_value);
}

```

In ladder logic, CKSM calculated using look-up table method according the contents of the frame CRC value calculated, the method process is simple, fast operation, but the program ROM space occupied by a larger space on the procedures required occasions, please used it with caution.

ASCII mode check (LRC Check)

Check code (LRC Check) is the results combine from the Address to the Data Content, such as the communication of information 9.6.2 above the parity-check codes: 0x02 +0 x06 +0 x00 +0 x08 +0 x13 +0 x88 = 0xAB, and then take the supplement 0xAB Code = 0x55.

9.8 Communication address description

1. Communication data address definition

This part defines the address data of communication, used to control the frequency converter, get status information of the frequency converter and set parameters of the frequency converter.

(1) The rules of parameter address

The number of parameters corresponds to its register address, but need to convert hexadecimal, such as the serial number of F5.06 is 59, 003AH in hexadecimal. High and low bytes of the scope are as follows: high-byte - 00 ~ 01; low byte - 00 ~ FF. Note: Some parameters should not be modified when the frequency converter in running status; some parameters can't be modified all time; pay attention to the scope of parameter settings, units and instructions when change the function code parameters.

In addition, operate the EEPROM frequently will reduce the use life of EEPROM, some parameters were no need to store under communication mode, simply change

the chip value of RAM is enough to meet the application requirements. Change the highest bit of address bit from 0 into 1 can achieve this function. Such as: function code F0.07 is not stored in EEPROM only modify the values in RAM can be set to address 8007H; the address only used to write the RAM chip.

Other function address description:

Function	Address	Data description	(R/W)
Communication control command	1000H	0001H: Forward run	W/R
		0002H: Reverse run	
		0003H: Forward jog	
		0004H: Reverse jog	
		0005H: Stop	
		0006H:Free park(emergency shutdown)	
		0007H: Fault reset	
		0008H: jog stop	
Frequency converter Status	1001H	0001H: in forward run	R
		0002H: in reverse run	
		0003H: standby status	
		0004H: in fault status	
Address	2000H	Communications settings range (-10000 ~ 10000) Note: The communication setting is the percentage of relative value (-100.00%~100.00%), communication can write operation. When configured as a frequency source, the relative frequency is the largest (F0.04) of the percentage; as FID or given feedback, the relative percentage of the FID. Which, FID and FID values of a given feedback value, are the form of percentages calculated FID	W/R
Run/Stop parameters description	3000H	Running frequency	R
	3001H	Set frequency	R
	3002H	Bus voltage	R
	3003H	Output voltage	R
	3004H	Output current	R
	3005H	Running speed	R
	3006H	Output power	R
	3007H	Output torque	R
	3008H	FID value given	R
	3009H	FID feedback value	R
	300AH	Signs the state of input terminal	R
	300BH	Signs the state of output terminal	R
	300CH	Analog AI1	R
	300DH	Analog AI2	R
	300EH	Reservation	R
	300FH	Reservation	R
3010H	Reservation	R	
3011H	Reservation	R	

NVF2G series frequency converter

Function	Address	Data description	(R/W)
	3012H	current speed of Multi-speed	R
Fault address of frequency converter	5000H	Fault code and function code information menu of the serial number of the same type of fault, but it returned to the host computer is hexadecimal data, rather than failure.	R
Communication error address of Modbus	5001H	0000H: No fault 0001H: password error 0002H: command code error 0003H: CRC checksum error 0004H: illegal address 0005H: illegal data 0006H: Invalid parameter changes 0007H: the system is locked 0008H: Frequency converter busy (EEPROM are stored in)	R

When error happened in communication, the frequency converter will send the error code in fixed format response to the control system to let the control system know the error. Regardless of the command code "03" or "06", the frequency converter send the command is "06" back, and the address is fixed to 0x5001. For example:

ASCII Slave failure response

START	‘:’
ADDR	‘0’
	‘1’
CMD	‘0’
	‘6’
Fault return address Hi.	‘5’
	‘0’
Fault return address Lo.	‘0’
	‘1’
Error code Hi.	‘0’
	‘0’
Error code Lo.	‘0’
	‘5’
LRC CHK Hi	‘A’
LRC CHK Lo	‘3’
END Lo	CR
END Hi	LF

Meaning of error code:

Error code	Description
1	Password error
2	Command code error

NVF2G series frequency converter

3	CRC checksum error
4	Illegal address
5	Illegal data
6	Change the parameter invalid
7	System is locked
8	Frequency converter busy (EEPROM is stored in)

9.9 Wiring description

9.9.1 Topology structure

No repeater, RS-485-Modbus has a main cable connect with other units (through daisy-chain). Main cable (bus) may be very long. Its two ends must connect end terminals.

Repeater also can be used between several RS-485 Modbus, and every slave's address in system must be unique, that is the basic of Modbus serial communication.

9.9.2 Length

Length of main terminal cables must be limited. Maximum length is related to baud rate, cable specification (capacitance or impedance), load number and network configuration (2-wire or 4-wire).

For AWG26 (or even thick) cable of high baud rate (eg. 9600bps), the maximum length is 1000m. Branch must be short, generally no longer than 20m. If use subscribers tap of n-branch, the length of each branch is limited in 40m/n.

9.9.3 Earth

Common circuit (of signal and optional power) must be connected to earth directly. It is better to earth the whole cable in a point. Generally this earthing point is located in master station or subscribers tap.

9.9.4 Cable

Modbus cable in serial communication must be shielded. Each cable end must be earthed to protective ground. If connector is used, its shell must be earthed to cable shield. RS485-Modbus must use a pair of balanced line and a third cable (used as common end).

For RS485-Modbus communication, a cable of enough diameter should be used to transfer maximum length (1000m), AWG24 can meet the requirement of Modbus communication.

Appendix A Optional devices

This chapter describes peripheral devices of the frequency converter, please read the contents of this chapter carefully before using the frequency converter.

A.1 Peripheral Devices connection diagram

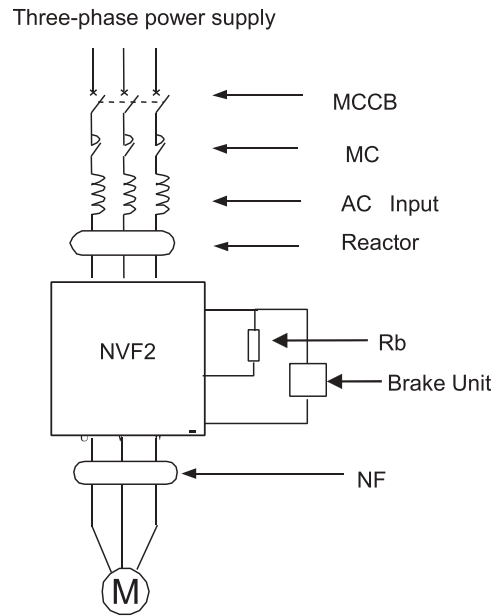

A.2 Peripheral devices table

Name	Usage	Frequency converter
Circuit breaker	Cut off the frequency converter input power fast	According to the capacity
EMC noise filter	The noise filter conforms to EMC specification	
Surge voltage suppression filter	Inhibit the output surge voltage of frequency converter	
DC reactor to improve Power factor	To improve input power factor (integrated power factor of about 95%) and use it with power	
AC input reactor to improve power factor	To improve input power factor (integrated power factor of about 95%) and use it with power	
Noise filter	Used to reduce noise interference	Applied to all Frequency converter
Linear noise filter	Used to reduce noise linear	110kW and below
Braking resistor	Used to improve the braking capacity of frequency converter (for high inertia loads or the reverse of the load)	
Braking unit	Braking resistor unit and brake use	110kW and below
Frequency setting potentiometer	Used to adjust the frequency converter frequency	Applied to all Frequency converter
Tachometer	Dedicated tachometer (DC 0V~10V), dynamic / digital display DC voltage meter	
Voltage Meter	Dedicated voltage meter (DC 0V~10V), dynamic / digital display DC voltage meter	
Ammeter	Dedicated ammeter (DC 0V~10V), dynamic / digital display DC voltage meter	
Keyboard plate	If operation panel of frequency converter needed to be installed on the door of control cabinet, or control the cabinet for remote operation, keyboard plate is needed.	Applied to all Frequency converter
Extended display line	Use as extended line for remote monitoring or when display panel need to be pulled out	According to actual condition

A.3 Braking resistor selection

Voltage (V)	Motor power (KW)	Resistor (Ω)	Resistor's power (W)
380	1.5	400	250
	2.2	250	250
	3.7	150	400
	5.5	100	500

Voltage (V)	Motor power (KW)	Resistor (Ω)	Resistor's power (W)
380	7.5	75	800
	11	50	1000
	15	40	1500
	18.5	30	4000
	22	30	4000
	30	20	6000
	37	16	9000
	45	13.6	9000
	55	10	12000
	75	6.8	18000
	90	6.8	18000
	110	6	18000

A.4 Leakage protector

Because of the electrostatic capacitance existed in internal part of the frequency converter and motor, both input line and output line, and high frequency carrier the frequency converter used, the frequency converter has large leakage current to ground, especially large capacity frequency converter, those sometimes lead to the protection circuit malfunction.

When you met those problems, you can reduce the carrier frequency and short the wire, besides you can install the leakage protector. The leakage protector should be installed at input side of the frequency converter. The operating current of leakage protector should be larger than 10 times of the leakage current of circuit without the frequency converter.

Appendix B Frequency converter Maintenance

This chapter describes basic maintenance knowledge of the frequency converter. Please read the contents carefully before using the frequency converter. The frequency converter is a product of integration of power electronic technology and microelectronic electrical technology. In order to prevent damaged caused by temperature, humidity, dust, dirt and vibration, ambient impact and components aging, user must perform maintenance work.

B.1 Inspection Items

B.1.1 Daily Inspection maintenance, please check:

- 1) If the motor runs under the command.
- 2) If there is abnormal at the install places.
- 3) If there is abnormal in the cooling system.
- 4) If there is any abnormal vibration of the sound.
- 5) If there is overheating and discoloration.
- 6) If there is input voltage of the frequency converter.

B.1.2 Regular Inspection maintenance

Firstly power supply must be cut off, and then inspection and maintenance work can be carried out until there is no display on the key board and the voltage measured by multimeter between $\ominus+$, $\ominus-$ of main circuit is below 36V, that is to avoid injury caused by the retained voltage of capacitor.

- 1) Cooling system: please clean air filters and check the cooling fan.
- 2) The screws and bolts: because of vibration, temperature changes and so on, screws and bolts and other fixed components may be loose, check whether they are reliable tightening, and tight them with tightening screw
- 3) Check whether the conductor and insulator material being corrosion and damage
- 4) Measure insulation resistance
- 5) Check whether there is any color change, smell, bubbling, and leakage on filter capacitor

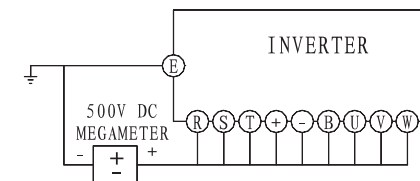

Fig. B.1 Insulation resistance measurement

B.2 Clear dust

- 1) Please always keep frequency converters running in a clean state.
- 2) When the clean the frequency converter, wipe dirty areas gently by soft cloth with Neutral detergent or amino alcohol.
- 3) Acetone, benzene, toluene and solvents like alcohol, can cause transducer surface paint peeling, Benzene toluene acetone and alcohol solvent, such as the surface will cause paint peeling, please do not use those wipe part of the operation panel display and other parts of, otherwise, will damage these parts.

B.3 Replace parts

There are many live parts in frequency converter, because of its composition and physical properties it will aging in a certain period of time, which would reduce the frequency converter's performance, even lead to failure, therefore, to preventive maintenance, there is the need to replace the main parts periodically. Shown as follows:

Parts	Replace period	Description
Cooling fan	2~3 years	Replace (after inspection)
DC filter capacitor	5 years	Replace (after inspection)
Other electrolytic capacitor	5 years	Replace (after inspection)
Relay	3 years	Replace (after inspection)

B.3.1 Cooling fan

Cooling fan used to cool hot parts of main circuit, its life is 10~35 thousand hours, therefore, in continuous operation, usually a period of 2-3 years should be taken to replace cooling fan. If there is abnormal sound and vibration, cooling fan must be replaced immediately

B.3.2 DC filter capacitor

Large-capacity aluminum electrolytic filter capacitors on DC, and aluminum electrolytic capacitors in control circuit, their characteristics will deteriorate because of the pulse of current, the surrounding environment, the impact of the use of conditions, (in the the air environment is usually used to replace a 5-year), and the deterioration of capacitance after a certain period of time to accelerate rapidly, so check the cycle for at least a year (nearly life hope that the following six months) check.

Inspection base of appearance

- 1) If there is expansion outside of the capacitors.
- 2) If there is visible board bending and cracks on the seal of the capacitors.
- 3) If there are other cracks in the appearance of packaging, color, such as leakage of liquid. When the capacitor's capacity is less than 85% of rated capacity, please replace the capacitors.

B.3.3 Relay

Because of poor contact, so a total of up to a certain number of switches (switching life) when it needs to be replaced.

Appendix C Quality commitment

The commitment of our product quality regulations are as follows:

1. Warrantee range: The frequency converter itself
2. Warranty period: 12 months from the date of purchase by the self - employed or 18 months from the date of production. Take the time as the first.
3. Repair service is charged even in warrantee period if the failure is caused by the following reasons:
 - 1) Improper operation, repair or alternation without our permission;
 - 2) Use the frequency converter exceeding the specification;
 - 3) Broken after purchase or improperly place (such as water, etc.);
 - 4) The work environment does not comply with the requirement on the user's manual;
 - 5) Wrong wring;
 - 6) Earth quake, fire, flood, lightning strike, abnormal voltage or nature disaster.
4. We have the right not to provide warranty service in the following occasion:
 - 1) The barcode, nameplate and other identifications of product are damaged or unable to indentify.
 - 2) The user has not paid according to "purchase and sale contract";
 - 3) User hide the improper operation appeared in process of the installation, wiring, operation, maintenance, etc.
5. We are entitled to ask the third party to repair the defective frequency converter. Associated service charges based on actual costs, subject to agreement to the agreement priority principle.
6. After-sale service can be provided by our company's sales, agents all over the country.

