



## NVF2G Inverter

### 1. General

NVF2G-series inverters are high-efficiency open-loop vector inverter researched and developed independently by our company. It has the features of high starting torque (0.5 Hz, 1.5 times of rated torque), strong overload capacity, flexible and convenient operation and forward PID and reverses PID, etc. This series of inverter can be divided into mini type, general type (heavy load) and fan and water pump type (light load), with the functions of strong load adaptability, stable and reliable operation and automatic energy-saving operation, etc. This product can be widely applied to electric drive field and automation control field, such as papermaking, textile, water supply, municipal administration, food, cement, chemical industry, printing and dyeing, metallurgy, mine and plastic machinery.

### Applicable equipment of the product

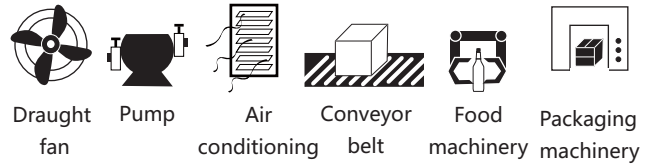

### 2. Product features

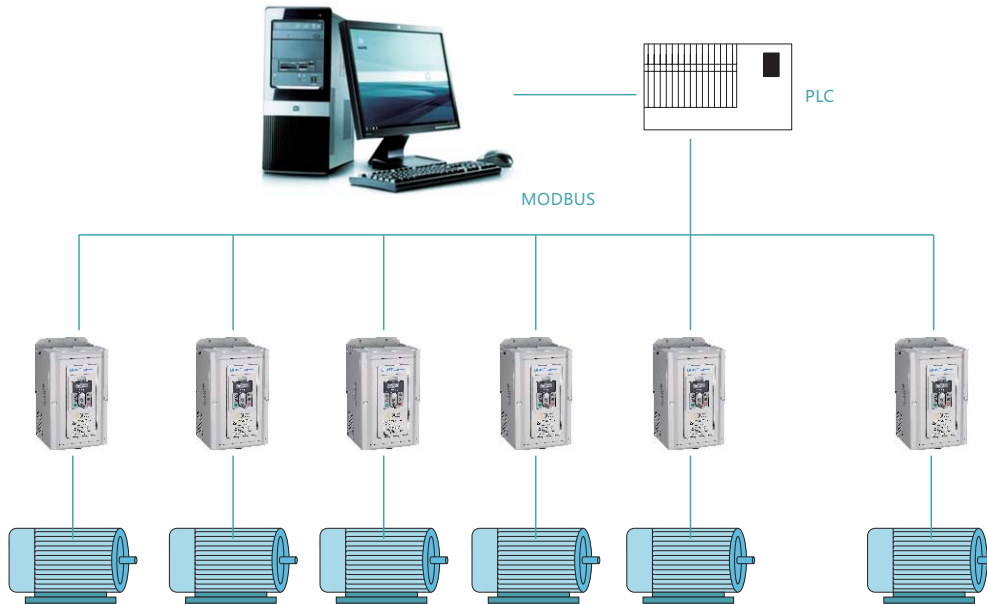

## 2.1 Excellent motor drive and control performance

- High starting torque: 0.5 Hz, 150% of rated motor torque;
- Superior energy-saving effect: the motor load more lighter more efficiency; Improve the operation efficiency of the motor through energy-saving control; the motor still operates under high-efficiency status regardless of the changes of load;
- Accurate auto tuning function: it can accurately conduct overall and static auto tuning of motor parameters with convenient debugging and simple operation, which can improve the control accuracy and response speed;
- Speed tracking: during the restarting after recovery from the momentary power interruption, it can judge the rotate direction and speed of motor and continue to operate smoothly;
- External DC electric reactor (over 110 kW) can effectively restrain higher harmonic.
- The exclusive dead time compensation technology can increase the output torque;
- Wide carrier frequency: (1-15) kHz, can effectively reduce the operation noise of motor;
- Ultra-strong overload capacity -- Maintain 1 min under 150% of rated current; in heavy load, it is uneasy frequently to trip overload protection and ensures the continuous and stable operation of the equipment;
- Real-time load monitoring -- Real-time monitoring of bus bar voltage and motor current to ensure stable start and stop and quick tracking.

## 2.2 High reliability design

- Design of the scope of universal input voltage: The fluctuation range of input voltage can reach up to  $\pm 15\%$ ;
- The function of input filtration can reduce harmonic interference effectively;
- The function of automatic voltage regulation (AVR) and automatic current limiting can make the system more stable;
- Perfect protection function and fault diagnosis system provide safe and reliable guarantee for the equipment.

## 2.3 Various application functions

- It adopts RS-485 communication interface and standard MODBUS communication protocol and can take networked automation control with external PLC equipment.
- It has wobble frequency, which is available for textile industry;
- The efficiently energy saving can be achieved by the built-in intelligent PID control and dormancy function;
- Simple PLC control: The inverter can operate in variable speed according to certain rule through simple PLC function; It not only can define one circular multistage frequency into the function code, but also can define the operation time, direction and number of cycles of the multistage frequency into the function code;
- Modular design: The NVF2G series inverter integrates the modular design that easy to be assembled and disassembled with the dismountable air heater and operation keyboard, which is easy for maintenance and usage;
- Design of common DC bus bar: Many inverters can be connected in parallel through common DC bus bar to share the feedback energy of braking, avoid overvoltage, stabilize the DC bus bar voltage of single inverter and make the equipment operate continuously and stably.

## 2.4 Ultra-strong environmental suitability:

- The inverter should be used at an ambient temperature of  $-10^{\circ}\text{C}$  to  $+40^{\circ}\text{C}$  and derated by 1% per  $1^{\circ}\text{C}$  when over  $40^{\circ}\text{C}$ ;
- The input range of wide voltage is the 15% fluctuation range of 380V, which is available for various civil and industrial power grid;
- Circuit board is processed with conformal coating to make it available for various complicated working conditions.

### 3. Various software functions

#### Speed tracking operation

**Start with the speed of motor under coast stop**

The motor under coast stop can be introduced to the set frequency automatically without the speed detector.

#### Frequency skip control

**Skipping the special frequency to prevent the vibration of mechanical system**

In order to prevent the vibration of mechanical system, it can automatically keep away from the resonance point when operating under the constant speed.

#### DC braking when starting

**Make the motor under coast stop stopping and restarting again**

Under coast stop, the motor will be automatically stopped by DC braking and re-started immediately when the rotate direction of the motor is uncertain.

#### Multistage speed operation

**The program can be operated according to the set multistage speed**

It can operate according to the frequency of internal storage based on the signal combination. Multistage speed control can be achieved through PLC, limit switch, etc.

#### Automatic voltage regulation (AVR)

**Ensure the stable output voltage during the operation of inverter**

During the voltage fluctuation of the power grid, the output voltage of invert will not change with it.

#### Energy-saving operation

**Automatic operation with peak efficiency**

Detect the load current and provide the motor with the peak efficiency voltage according to the load and rotate speed to achieve the most efficient energy saving operation.

#### Automatic current limiting

**Automatically limit the output current to prevent frequent overcurrent**

When the load fluctuation exceeds the current limit level, it will make automatic regulation to maintain the current within the allowed range.

#### Failure record

**Storage the fault information automatically**

When there is fault alarm, it will automatically record the current and voltage and fault type to provide reference for determining the fault cause.

#### Torque limit

**It will protect the machinery to ensure the reliable operation of machinery and equipment**

It is helpful to protect the machinery by controlling the torque generated by the motor within the set value.

#### Dormancy control of water pump

**To reduce the mechanical wear**

When the water consumption at night is less and the output frequency of inverter is lower than the dormancy frequency, the inverter will enter into dormancy status.

#### Frequency detection

**It is used to detect the frequency and is available for interlock of brake**

When the output frequency is higher than the set value, it will output signal and is available for the interlock control of equipment.

#### PID control

**Automatic process control**

It will conduct PID calculation in the inverter and take the calculation result as the frequency instruction to quantitatively control the pressure, flow and air volume, etc.

**Wobble frequency control**

**It is operated by swinging up and down by taking the set frequency as the center**  
 Wobble frequency is available for textile, chemical fiber and other industries and occasions needing traversing and winding function.

**Restraint of overvoltage**

**Prevent fault and tripping due to overvoltage**  
 It is valid to punch and other operations that regenerated repeatedly due to the crank motion; According to the regeneration status, it will increase or decrease the operation frequency to restrain the overvoltage.

**Fault restoration**

**To improve the reliability of continuous operation**  
 Even if the inverter is detected for fault, it will reset automatically after auto-diagnosis to restart the operation without stopping the motor. The number of automatic reset is 3.

**Automatic torque boost**

**To increase the low-frequency output torque under V/F control mode**  
 It is used for setting the manual/automatic torque boost setting under V/F control mode to effectively increase the low-frequency torque of inverter.

## 4. Main parameter and technical performance

### 4.1 NVF2G Inverter specifications

#### 4.1.1 General type (T), fan and water pump type (P)

Input voltage class	380V				
Inverter power (kW)	1.5/PS4,1.5/TS4	2.2/PS4,2.2/TS4	3.7/PS4,3.7/TS4	5.5/PS4	5.5/TS4
Applicable motor power (kW)	1.5	2.2	3.7	5.5	5.5
Rated output current (A)	3.7	5	9	11	13

Input voltage class	3-phase	380V				
Inverter power (kW)	7.5/PS4,7.5/TS4	11/PS4	11/TS4	15/PS4,15/TS4	18.5/PS4,18.5/TS4	22/PS4,22/TS4
Applicable motor power (kW)	7.5	11	11	15	18.5	22
Rated output current (A)	17	22	25	32	37	45

Input voltage class	3-phase	380V				
Inverter power (kW)	30/PS4,30/TS4	37/PS4,37/TS4	45/PS4,45/TS4	55/PS4,55/TS4	75/PS4	75/TS4
Applicable motor power (kW)	30	37	45	55	75	75
Rated output current (A)	60	75	90	110	140	150

Input voltage class	3-phase	380V				
Inverter power (kW)	90/PS4,90/TS4	110/PS4,110/TS4	132/PS4,132/TS4	160/PS4,160/TS4	185/PS4,185/TS4	200/PS4,200/TS4
Applicable motor power (kW)	90	110	132	160	185	200
Rated output current (A)	176	210	253	300	340	380

Input voltage class	3-phase	380V				
Inverter power (kW)	220/PS4,220/TS4	245/PS4,245/TS4	280/PS4,280/TS4	315/PS4,315/TS4	355/PS4,355/TS4	400/PS4,400/TS4
Applicable motor power (kW)	220	245	280	315	355	400
Rated output current (A)	420	470	520	600	640	690



#### 4.2 Standard technical features

<b>Input and output features</b>	Input voltage range: 380V/220V(±15%)
	Input frequency range: (47-63)Hz
	Output voltage range: 0- rated input voltage
	Output frequency range: General type: (0-400)Hz; Fan and water pump type: (0-120)Hz
<b>Peripheral interface</b>	Programmable digital input: Mini type: 5-route; General type, fan and water pump type: 6-route
	Programmable analog quantity input: AI1: (0-10)V input; AI2: (0-10)V or (0/4-20)mA; AI1 + AI2
	Open collector output: 1-route output
	Relay output: Mini type: 1-route output; General type, fan and water pump type: 2-route output
	Analogue output: For 2-route output, (0-10)V or (0/4-20)mA (mini type; 1-route) can be selected
<b>Operation functions and features</b>	Torque boost: Automatic torque boost; Manual torque boost of 0.1% - 30.0%
	Dynamic braking: Built-in or external brake unit, external connection with brake resistance
	DC braking: Start and stop are selectable separately; motion frequency (0-10)Hz, brake current (0-150)% , actuation time (0.0-50.0)s
	Jog control: Jog frequency range: (0-400)Hz, time for jog acceleration and deceleration (0.1-3600.0)s
	Multistage speed operation: Multistage speed operation can be achieved through the built-in simple PLC or controlling multi-function terminal.
	Automatic voltage regulation (AVR): When the network voltage changes, it can keep the output voltage stable automatically
	Automatic current limit: To automatically limit the current during the operation to prevent fault and tripping due to frequent overcurrent
	Built-in PID controller: It can constitute a closed-loop control system conveniently
	Self-defined JOG function key: The JOG key can be set as jog operation or switch from forward and reverse operation
Protection functions: It can provide over 20 kinds of fault protection functions: overcurrent, overvoltage, undervoltage overheating, default phase, overload, PID disconnection and other protection functions,	
<b>Technical features</b>	Control mode: Non-PG vector control, V/F control, torque control
	Overload capacity: Mini type and general type: 150% rated current for 1min; Fan and pump type: 120% rated current for 1 min
	Starting torque: Non-PG vector control: 0.5 Hz /150% (Rated torque)
	Speed regulation ratio: Non-PG vector control: 1: 100; V/F control: 1:50
	Speed control precision: (non-PG vector control): ±0.5% maximum speed
	Carrier frequency (1-15) kHz
<b>Operation environment</b>	Temperature: The inverter should be used at an ambient temperature of -10°C to +40°C and derated by 1% per 1°C when it is over 40°C
	Humidity: Relative air humidity of the operation environment ≤ 90%, without moisture condensation
	Altitude: The inverter can achieve the rated power when installed below the altitude of 1000m. It should be derated by 10% per 1000m when over 1000m.
	Shock and vibration: The inverter should not be dropped to the ground or subjected to sudden shock. It should not be installed in places where vibration may occur.
	Electromagnetic radiation: The inverter should not be installed adjacent to electromagnetic radiation protection
Air pollution: The inverter should not be installed in places with air pollution, such as dust or corrosive gas atmosphere	
<b>Structure</b>	Protection degree: IP20
	Brake units Standard braking unit for model under 22 kw; standard braking unit for model equal to or above 22 kW
	Cooling mode: High-speed DC fan is used for the cooling of the whole NVF2G series inverter

## 5. Wiring diagram

### 5.1 Standard wiring diagram

#### 5.1.1 Standard wiring diagram of general type and fan and water pump type

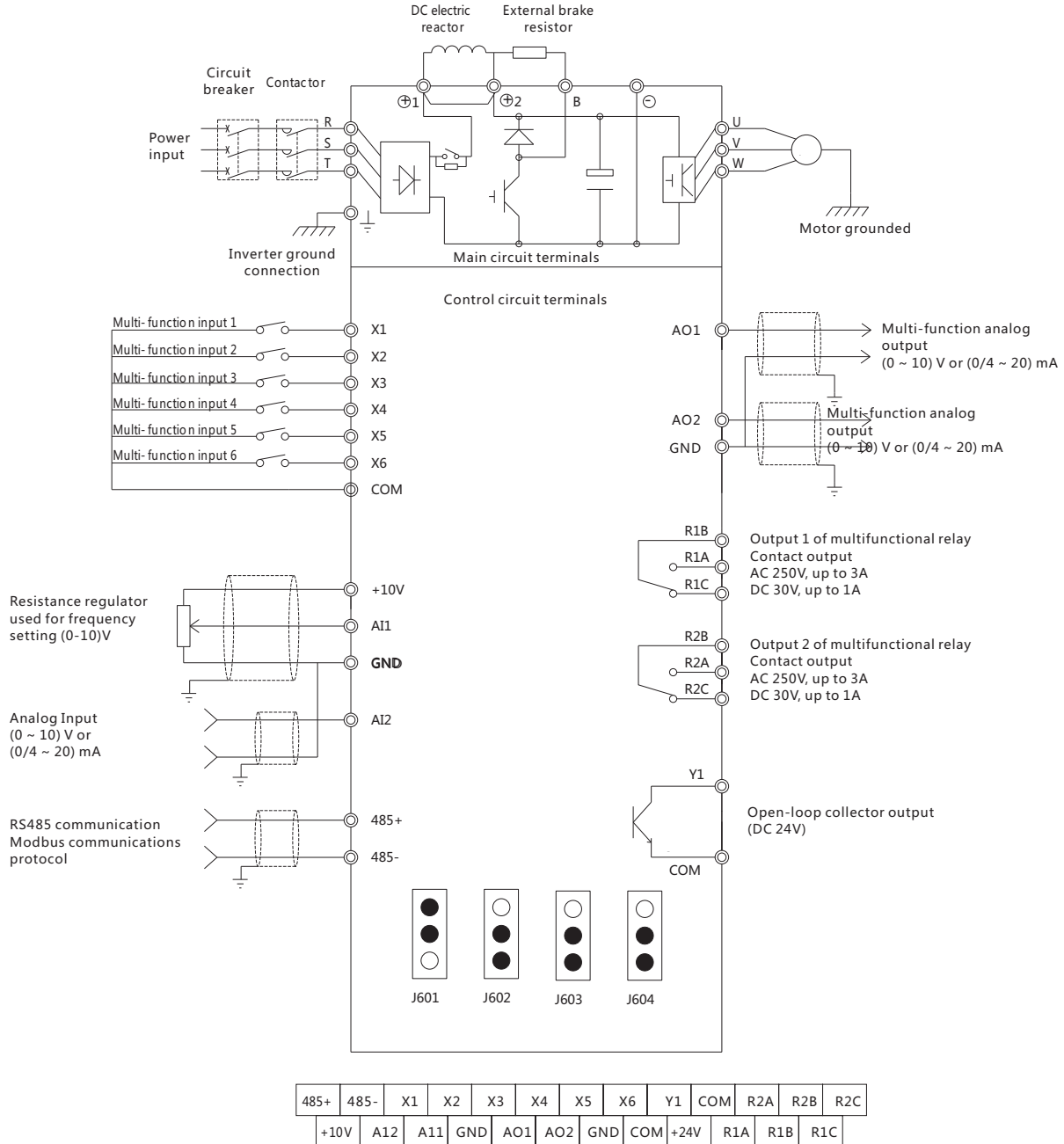

#### Arrangement of the corresponding control terminal

J601 position (AI1 interface): Connect Terminal 1 with Terminal 2: 0V-10V analog voltage input of AI1;

Connect Terminal 2 with Terminal 3: input of the potentiometer on panel

J602 position (AI2 interface): Connect Terminal 1 with Terminal 2: 0V-10V analog voltage input;

Connect Terminal 2 with Terminal 3: 0/4 mA-20 mA analog current input

J603 position (AO1 interface): Connect Terminal 1 with Terminal 2: 0V-10V analog voltage output;

Connect Terminal 2 with Terminal 3: 0/4 mA-20 mA analog current output

J604 position (AO2 interface): Connect Terminal 1 with Terminal 2: 0V-10V analog voltage output;

Connect Terminal 2 with Terminal 3: 0/4 mA-20 mA analog current output

Corresponding models: NVF2G-1.5/PS4~400/TS4 , NVF2G-2.2/TD2~3.7/TD2

Notes: The main power lines of single-phase inverter connect with Terminal R and Terminal T.



5.2 Terminal annotation

5.2.1 Terminal annotation of main circuit

Terminal Symbol	Terminal name and description
R,S,T	Input terminal of AC power supply, used for connecting with 3-phase 380V power-frequency power supply (single-phase 220V power supply is connected with Terminal R and Terminal T)
⊕1,⊖	Input terminal of DC power supply, used for connecting with external brake unit
⊕1,B	Connect with braking resistor terminal
⊕1,⊕2	DC reactor connector
U,V,W	AC output terminal, used for connecting with the motor
⏟	Grounding terminal, used for the grounding of inverter

5.2.2 Description of the control circuit terminal

Terminal Symbol	Terminal name	Description
R1A,R1B,R1C	Relay output	RA and RB are N/O contract group; RB and RC are N/C contract group
R2A,R2B,R2C		The functional parameters are set through F6.01 and F6.02
Y1,COM	Open collector output	Functional parameters are set through F6.00, the factory default value is signal output under forward status
485+,485- 10V	Serial communication terminal Power supply used for frequency setting	Terminal serially communicated with the external part Potentiometer of 4.7kΩ-10kΩ connected with AI1,AI2 and GND
AI1,GND	Input terminal of analog signal	It is used to connect with potentiometer or 0V-10V signal to be taken as the frequency setting, set or feedback of PID
AI2,GND	Input terminal of analog signal	It inputs signals of 0V-10V and 0/4mA- 20mA to be taken as the frequency setting, set or feedback of PID
AO1,AO2	Output terminal of analog signal	AO1 and AO2 connecting with the analog signal meter of DC 0V-10V or 0/4mA-20mA can be used for indicating the operation frequency, output current, output voltage, etc.
X1	Multi-function input terminal	The default set is forward operation
X2	Multi-function input terminal	The default set is reverse operation
X3	Multi-function input terminal	The default set is forward jog
X4	Multi-function input terminal	The default set is reverse jog
X5	Multi-function input terminal	The default set is fault resetting
X6	Multi-function input terminal	The default set is external fault input
COM	Common point for multi-functional input terminals	Fit the use of X1-X6
24V,COM	24V output of auxiliary power supply	24V output of DC power (≤50mA)

6. Mounting dimensions (mm)

6.1 Product appearance diagram

Dimension of the hole on NVF2G display box

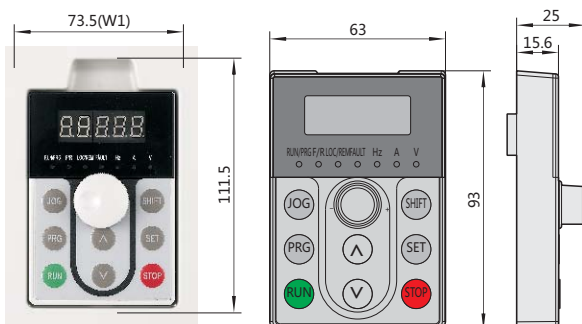

Dimensions of panel hole

NVF2G-2.2/TD2~3.7/TD2 and NVF2G-1.5/PS4~11/PS4

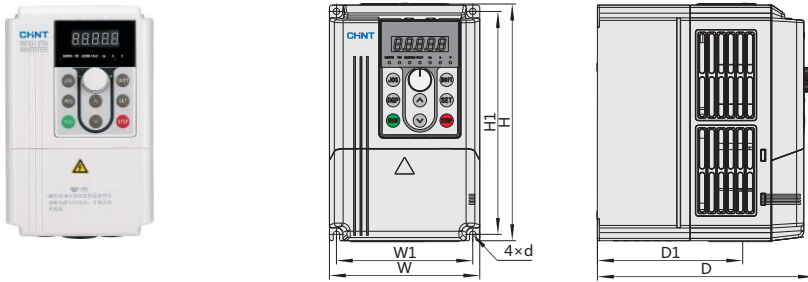

NVF2G-11/TS4~37/PS4

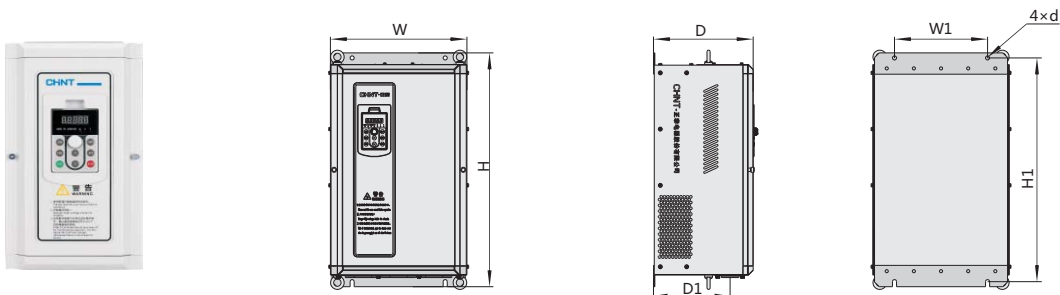

NVF2G-37/TS4~75/PS4

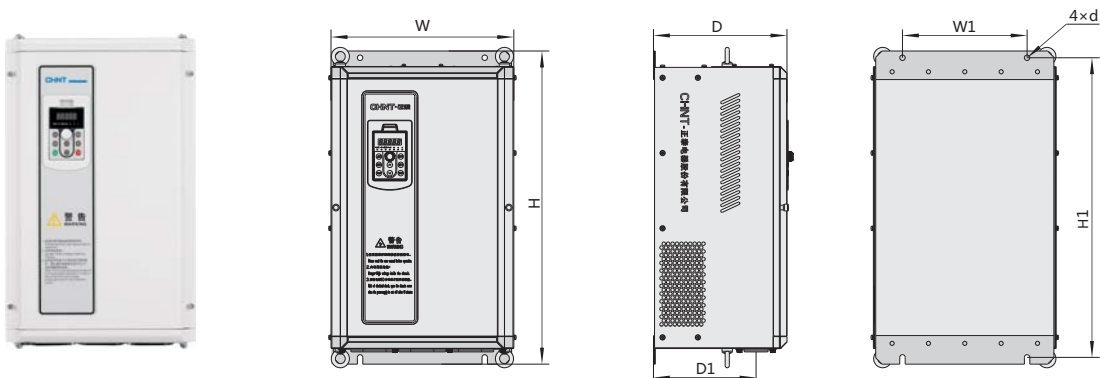

NVF2G-75/TS4~NVF2G-400/TS4

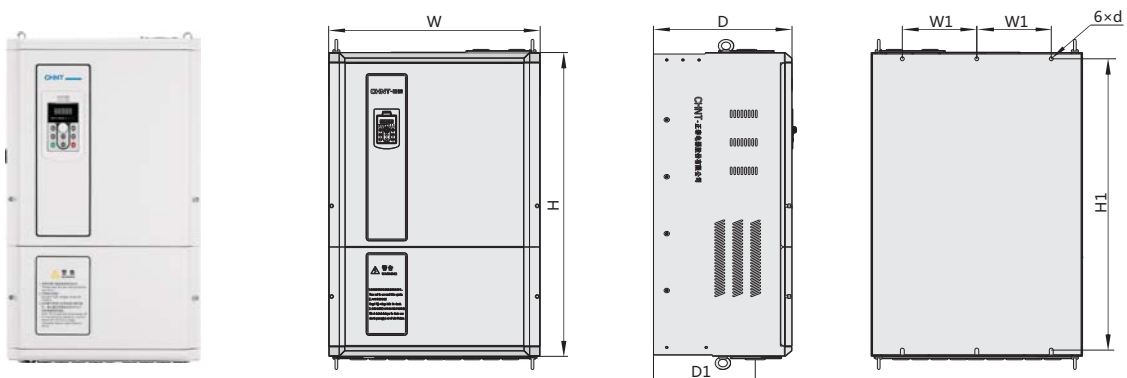



### 6.2 Product mounting dimensions

Product specifications	W	H	D	W1	H1	Mounting holed	Weight (kg)
NVF3-1.5/PS4 (1.5/TS4) (2.2/PS4) NVF3-2.2/TS4 (3.7/PS4) NVF3-3.7/TS4 (5.5/PS4) NVF3-5.5/TS4 (7.5/PS4) NVF3-7.5/TS4 (11/PS4) NVF3-11/TS4 (15/PS4) NVF3-15/TS4 (18.5/PS4) NVF3-18.5/TS4 (22/PS4) NVF3-22/TS4 (30/PS4) NVF3-30/TS4 (37/PS4) NVF3-37/TS4 (45/PS4) NVF3-45/TS4 (55/PS4) NVF3-55/TS4 (75/PS4) NVF3-75/TS4 (90/PS4) NVF3-90/TS4 (110/PS4) NVF3-110/TS4 (132/PS4) NVF3-132/TS4 (160/PS4) NVF3-160/TS4 (185/PS4) NVF3-185/TS4 (200/PS4) NVF3-200/TS4 (220/PS4) NVF3-220/TS4 (245/PS4) NVF3-245/TS4 (280/PS4) NVF300-280/TS4 (315/PS4) NVF3-315/TS4 (355/PS4) NVF3-355/TS4 (400/PS4) NVF3-400/TS4	118	187	173	107	175	Φ5	2.4
	155	247	189	140	232	Φ6	3.6
	191	378	183	90	362	Φ9	10.5
	215	426	213	120	407	Φ10	15
	300	527	230	166.6	506	Φ10	26
	352	603	257	240	577	Φ10	34
	406	631	272	126	600	Φ10	58
	470	807	352	150	769	Φ12	108
	540	892	390	180	848	Φ12	121
	710	1020	386	250	978	Φ13	171
	734	1213	428	250	1152	Φ16.5	280

### 7. Optional accessories of peripheral equipment

Name of accessories	Functions of accessories
Circuit breaker	It will protect the power system when short circuit occurred. It must be connected between the AC reactors of the AC main circuit power supply, or be connected at the front of the inverter if there is no electric reactor.
AC input reactor	To increase the power factor of input power, reduce the higher harmonic and restrain the surge on the power supply of inverter.
DC reactor	1. To improve or restrain the aberration rate of the voltage of power grid and current waveform due to the pulse current generated at the charging and discharging of filter capacitor; 2. To reduce the amount of harmonic and increase the power supply quality of the power grid.
AC output reactor	1. It can effectively restrain the noise-grade vibration of motor; 2. It can effectively restrain the differential mode noise within 100KHz at the output side of the inverter; 3. It can effectively absorb surge voltage.
Brake units	1. It can control the pumping voltage of bus bar and has certain protective function to the inverter; 2. When frequent braking is needed, it can increase the braking capacity of inverter.
Braking resistor	It can consume the mechanical energy generated during braking as the thermal energy through brake resistor to reduce the deceleration time of drive system of the inverter.
Keyboard support plate	When the operation panel of inverter is needed to be installed on the door sheet of control cabinet or needed remote control of operation cabinet, it shall be installed through keyboard support plate.
Display extension cable	It is used as extension cable when using remote monitoring or pulling out the operation panel.

Selection table of accessories

Inverter	Selection of braking accessories		AC input electric reactor		AC output electric reactor		DC electric reactor					
	Configuration conditions of the braking unit (10% braking ratio)	Braking resistance		Configuration	Rated current (A)	Inductance (mH)	Configuration	Rated current (A)	Inductance (mH)	Configuration	Rated current (A)	Inductance (mH)
Resistance value (Ω)		Power (W)	Configuration									
2.2/TD2	Standard internal braking unit	70	260		11	1		11	0.9		—	—
3.7/TD2		40	390		18.5	0.6		18	0.5			
1.5/PS4,1.5/TS4	Standard internal braking unit (including 22/PS4 model)	400	260		3.7	2.239		3	2.1	Do not need to purchase DC electric reactor	—	—
2.2/PS4,2.2/TS4		250	260		5.5	2.18		6.3	1.5		—	—
3.7/PS4,3.7/TS4		150	390		9	1.85		11	1.1		—	—
5.5/PS4,5.5/TS4		100	520		13	1.56		16	0.8		—	—
7.5/PS4,7.5/TS4		75	780		18	1		18	0.65		—	—
11/PS4,11/TS4		50	1040		24	0.52		28	0.33		—	—
15/PS4,15/TS4		40	1560		34	0.397		35	0.25		—	—
18.5/PS4,18.5/TS4		32	4800		38	0.352		40	0.2		—	—
22/PS4,22/TS4	Selectable internal braking unit(including 110/PS4 model)	27.2	4800		50	0.26		50	0.18	Selectable external configuration (including 110/PS4 model)	70	0.9
30/PS4,30/TS4		20	6000		60	0.24		63	0.09		80	0.86
37/PS4,37/TS4		16	7000		75	0.235		80	0.08		100	0.7
45/PS4,45/TS4		13.6	9600		91	0.17		100	0.06		120	0.58
55/PS4,55/TS4		10	12000		112	0.16		125	0.04		146	0.47
75/PS4,75/TS4		6.8	12000		150	0.12		160	0.035		160	0.36
90/PS4,90/TS4		6.8	12000		200	0.0705		200	0.023		180	0.33
110/PS4,110/TS4	Selectable external braking unit ( including 315/PS4 model )	6	20000		224	0.0692		224	0.016	Standard external configuration	250	0.24
132/PS4,132/TS4		6	25000		280	0.0503		280	0.016		280	0.24
160/PS4,160/TS4		2.5	50000		315	0.0447		315	0.013		340	0.16
185/PS4,185/TS4					400	0.0352		400	0.011		460	0.09
200/PS4,200/TS4					400	0.0352		400	0.011		460	0.09
220/PS4,220/TS4					450	0.0313		560	0.009		500	0.82
245/PS4,245/TS4					560	0.0251		600	0.008		600	0.072
280/PS4,280/TS4					560	0.0251		600	0.008		600	0.072
315/PS4,315/TS4	Selectable configuration of external braking unit				660	0.042		660	0.011	Standard internal configuration	1000	0.050
355/PS4,355/TS4					660	0.042		660	0.011		1000	0.050
400/PS4,400/TS4					800	0.035		800	0.009		1000	0.050
Corresponding physical diagram of each accessory												
Physical diagram of display extension cable and support plate of the panel												
Remarks: When the panel of inverter needs to be pulled out for control, it shall be noted specially when ordering and the length of the display extension cable shall be indicated.												



## 8. Ordering information

### 8.1 Type designation

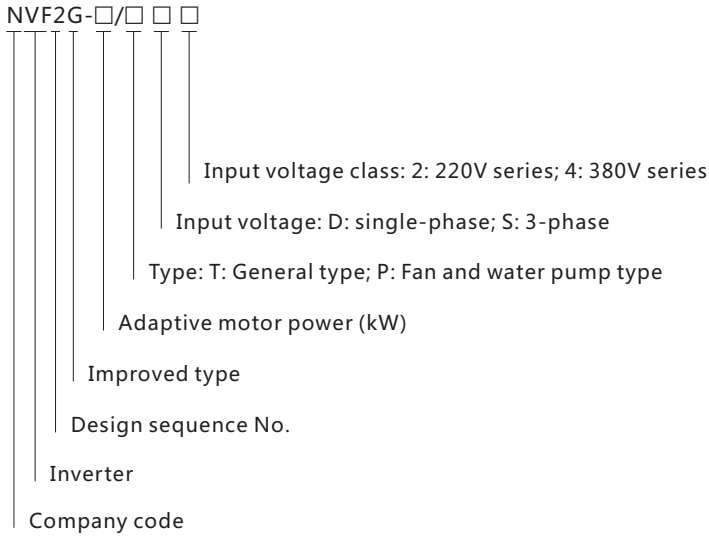

When ordering, you shall select the needed model and specification according to the illustration of model and implication:

For example:

single-phase 220V series: NVF2G-3.7/TD2

3-phase 380V general type: NVF2G-45/TS4

3-phase 380V fan and water pump type: NVF2G-55/PS4

### 8.2 Selection guidance

8.2.1 In order to ensure the reliable operation of inverter, the power of inverter must be equal or greater than the power of motor.

8.2.2 General-type inverter is mainly used for load excluding fan and water pump, such as: rolling mill, mixer, ball grinder, centrifugal machine and other heavy-load machine.

8.2.3 Fan and water pump type of inverter is mainly used for fan, water pump and other light-load machine.

## 9. Customized VFC control cabinet

A variety of VFC control cabinets can be specially ordered according to the production process requirements.

